

**AL600**  
Universal Hybrid Lift

**AL690**  
Side-Door Hybrid Lift

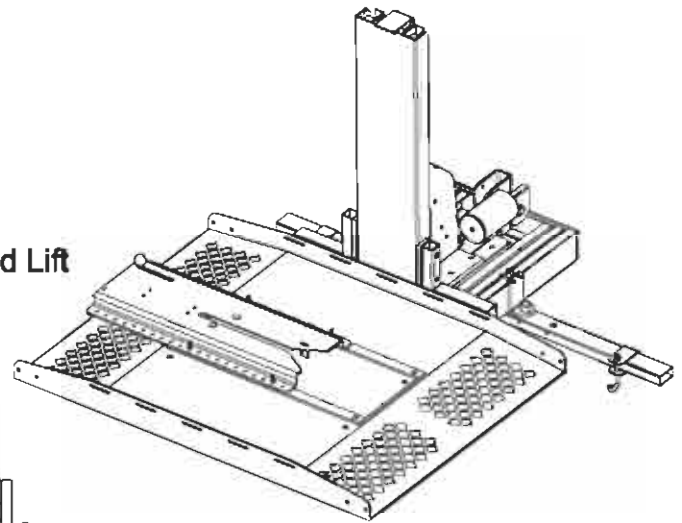

**AL650**  
Hybrid Pwerchair Lift  
w/ Docking Station

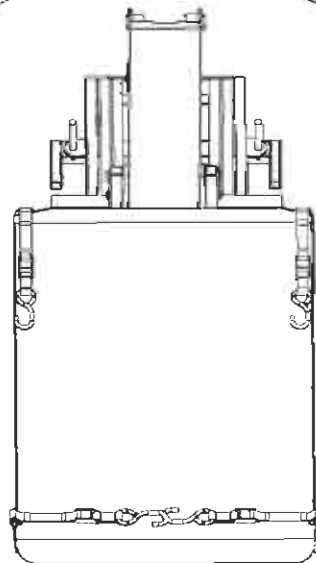

**Read manual thoroughly before attempting to install or operate lift.**

This manual has been provided to assist you with lift installation and operation. For further assistance please contact your authorized Harmar Mobility dealer or Harmar's Technical Services department.

Tel: 800.833.0478

Fax: 866.234.0478

Email: [tech@harmar.com](mailto:tech@harmar.com)

**Dealer:**

**Serial Number:**

# Unpacking the Lift

Lift Assembly

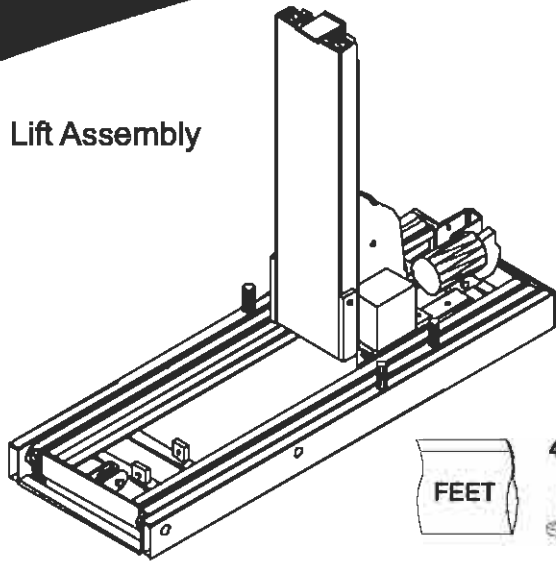

Hardware Pack

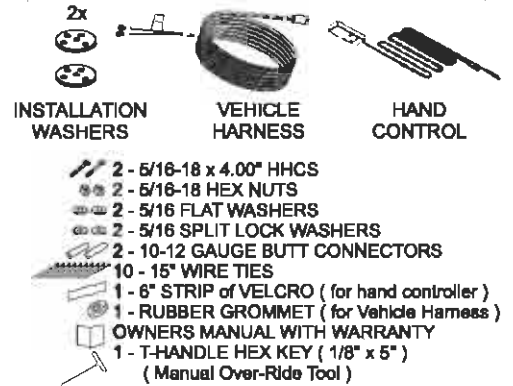

AL600

AL650

AL690

600 Platform

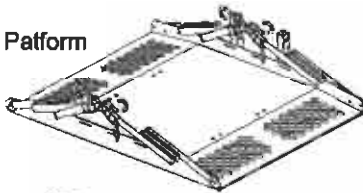

Leg Assembly

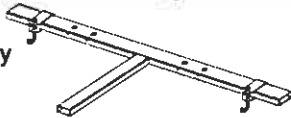

Foot Plate



Front Wheel Cradle  
(option for scooters)



- 4 - U-Bolts 1/4-20 Thread
- 8 - 1/4-20 Nut
- 8 - 1/4 Split Lock Washers
- 8 - Backing Plates



650 Platform

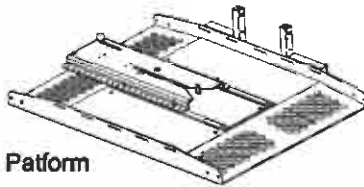

Leg Assembly

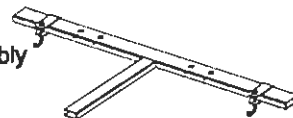

Foot Plate



Docking Plate Assy

- 4 - 1/4-20 x 2.25" Flat Head Ph
- 4 - 1/4-20 x 3.00" Flat Head Ph
- 6 - 1" Tall Spacer
- 4 - 1/2" Tall Spacer
- 4 - 1/4" Tall Spacer

690 Platform

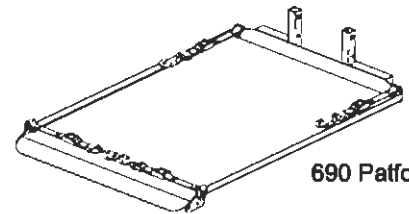

690 Front Leg Assembly

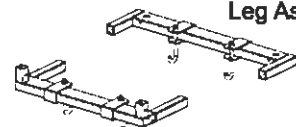

690 Rear Leg Assembly



- 4 - U-Bolts 1/4-20 Thread
- 8 - 1/4-20 Nut
- 8 - 1/4 Split Lock Washers
- 8 - Backing Plates



Be sure to check the contents of the box against the package checklist assuring that all parts are present. If any parts are missing, or damage is noted, contact your dealer immediately. DO NOT attempt to install or operate a lift with missing or damaged parts.

# Wiring the Vehicle

**Important Note: IMPROPER WIRING IS THE #1 CAUSE OF PROBLEMS IN THE OPERATION OF A VEHICLE LIFT. FOLLOW THE WIRING INSTRUCTIONS CAREFULLY**

Located in the hardware package is the vehicle wiring harness. The harness is manufactured to, and complies with the SAE J1128 requirements. The wire harness is approximately 23 ft. long and will accommodate most vehicles.

Your Heavy Duty Vehicle Harness has been left unassembled for ease of installation. The END CONNECTOR has been included separately from the wire harness to allow the installer to run the wire under and through the vehicle with the smallest hole possible. Follow these instructions to assure a proper installation.

Unwind the harness and lay it flat. One end of the harness has 2 covered pins. This is the lift end of the harness and goes to the middle of the vehicle, and inside to the rear cargo area.

Begin routing the wiring harness at the vehicle battery. Attach the black wire to the negative terminal on the battery. **Do not attach the red wire yet.**

Run the wiring harness under or when possible through the vehicle, back to rear cargo area. Always locate the wiring harness where it can not be snagged by road debris and away from the vehicles gas tank.

Through the vehicle is best for the AL600, gaining entry into the vehicle through the firewall. However if you wish to run the harness under the vehicle, a hole will most likely need to be drilled to get wire into the rear cargo area. If the harness is too long for the vehicle, coil the excess wire and secure it to the vehicle frame with the supplied tie wraps. **Do not cut or shorten the harness.**

Attach the red wire to the positive terminal on the battery.

Once the harness is run into the vehicle, remove pins' protective tubing.

Inspect the pins' retaining flanges. They may have become deformed while running them through the vehicle. These are critical to secure the pins inside the END CONNECTOR. Adjust as needed.

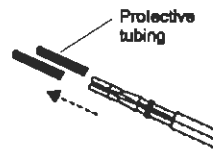

CORRECT

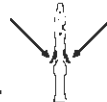

IF NEEDED



Flip open END CONNECTOR's hinged retainer. Insert pins as shown. B=BLACK, A=RED

Verify that wires cannot be pulled out by moderately pulling on the wire.

Be sure wire SEALS are inside connector, and close the END CONNECTOR's hinged retainer.

Plug connector into the lift.

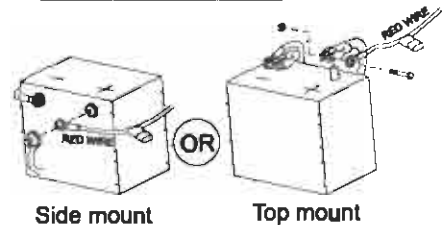
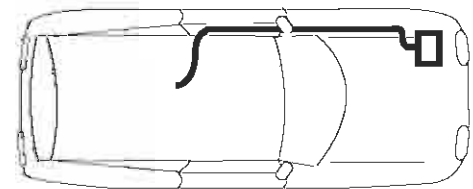
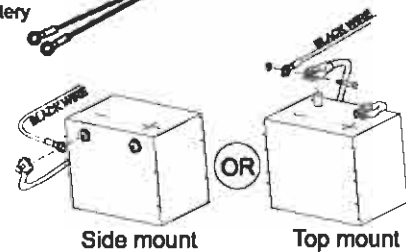
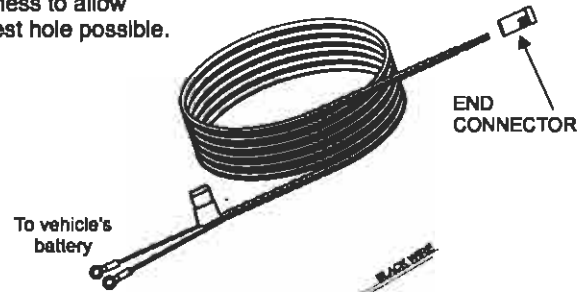
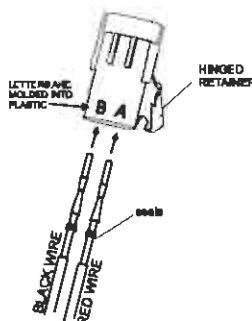

**Important Reminder: Never attempt to attach the wire harness to a secondary power source, The lift requires direct connection to the battery.**

**Caution: When the installation requires the wiring harness be run on the underside of a vehicle, route the harness away from the exhaust system, brake lines, fuel lines, gas tank, pinch points, and sharp edges. Locate the wiring harness where it can not be snagged by road debris.**

# Docking Station Height

# AL650

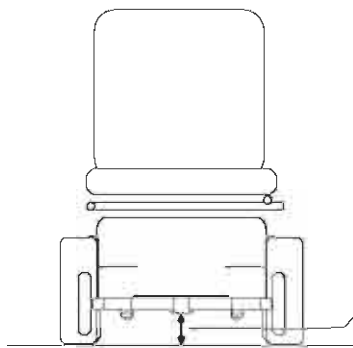
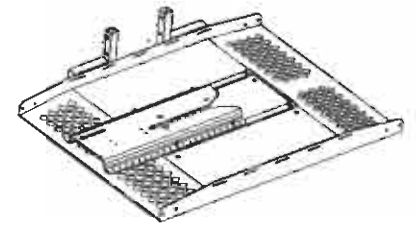



Measure distance of mounting surface to ground

PRIOR TO MOUNTING DOCKING PLATE TO CHAIR

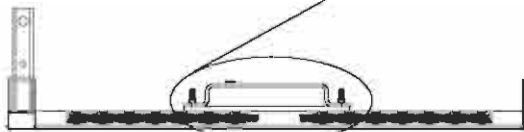
Ground clearance MUST be greater than or equal to 1.75"



Determine number of spacers and screw length required for your ground clearance

If ground clearance =	Then use:	Hardware Used: ( from hardware pack )
1.75" - 2"	No Spacers	Mounted on lift from factory  1.25" x4
2.25"	.25" spacers	
2.5"	.5" spacers	
2.75"	.75" spacers	
3"	1" spacers	 2.25" x4
3.25"	1" + .25" spacers	
3.5"	1" + .5" spacers	
3.75"	1" + .5" + .25" spacers	
4"	1" + 1" spacers	 3.00" x4
4.25"	1" + 1" + .25" spacers	

Remove Locking Device and insert appropriate number of spacers. Re-attach to platform. Change to longer screws if necessary

Add spacers here as required

Change to longer screws here as required

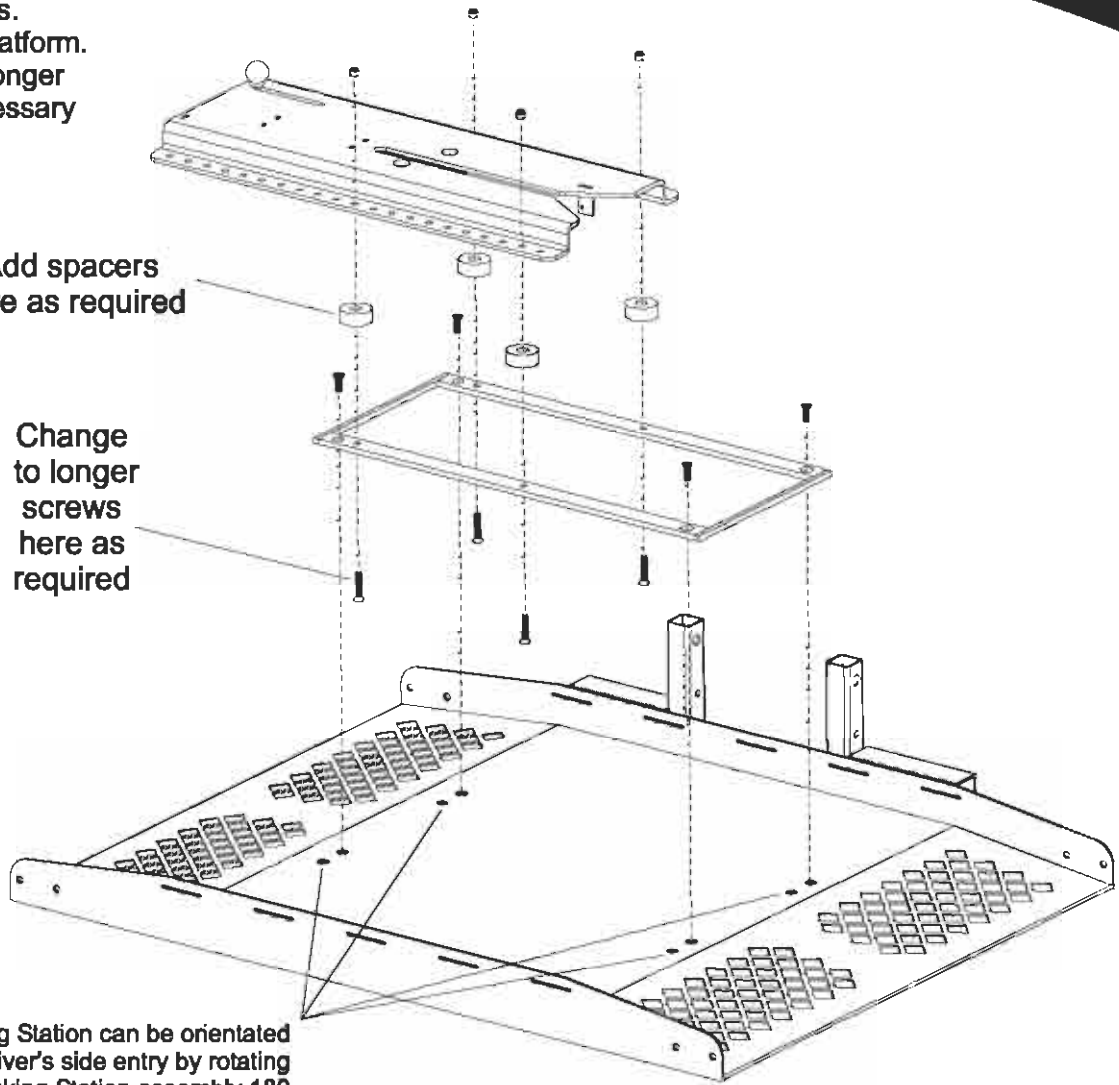

Docking Station can be orientated for driver's side entry by rotating Docking Station assembly 180 degrees and mounted to this second set of threaded locations on platform.

**Verify the head of the shoulder bolt is below the underside of the locking device. UP TO A 1/4" OF SPACE IS ACCEPTABLE**

Drive Chair onto Platform

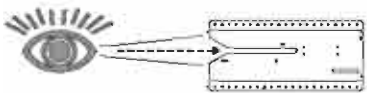

look down the entry point of the locking device

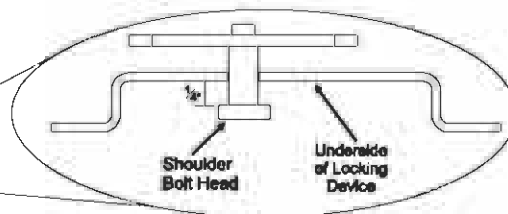
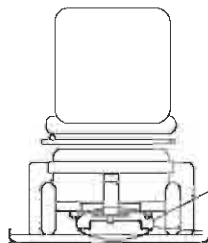

Perform lock down test on "Loading Chair - AL690" page to assure installation of Docking Device Plate and Locking Device are correct.

# Power Chair Preparation

# AL650

## CHOOSING A LOCATION and MOUNTING THE DOCKING DEVICE PLATE

**WARNING:** Do not attempt to use this automatic lock down device on any folding, or take apart chairs unless recommended by Harmar.

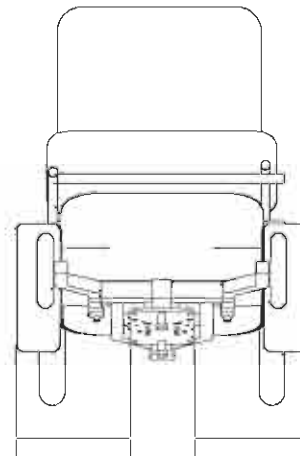
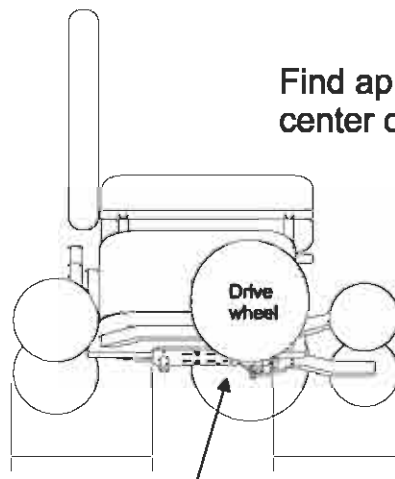

The closer the plate is positioned to the drive wheels, the easier the chair will be to engage the Locking Device

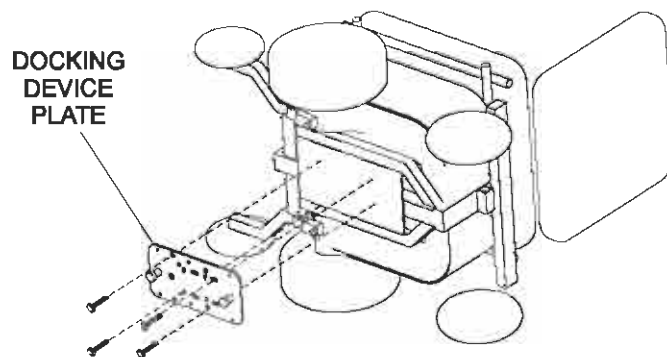

Use existing holes where ever possible.

If too little or no holes exist, holes need to be drilled. Remove power chair's batteries, and use plate as a template. Drill as required.

Attach to chair using supplied hardware.

4---1/4-20 x 1.00" HHCS

4---1/4-20 Nylock Nut

ATTACHED TO PLATE

There are 2 options on how to attach the strap hooks to the chair that are included with the lift.

**Anchor Plate:** The Anchor Plate is a flat plate that is 20" long with 2 slots in each end. This plate will work with any chair or scooter that has a center seat post that attaches to the bottom of the seat. Attach the Anchor Plate by the following steps.

1. Remove the seat from the chair and turn it over.
2. Loosen the screws that attach the plate to the bottom of the seat. Allow enough room to slide the Anchor Plate between the seat and the seat plate.
3. Attach the Anchor Plate in the center of the seat plate with the holes on each end extending evenly on each side of the seat.
4. Retighten the screws that hold the seat plate to the bottom of the seat.
5. Replace the seat on the chair.

The Anchor Plate should extend about 1-1/2" out from the side of the seat cushion. This will allow the user to attach the strap hooks to the Anchor Plate to secure the chair to the lift.

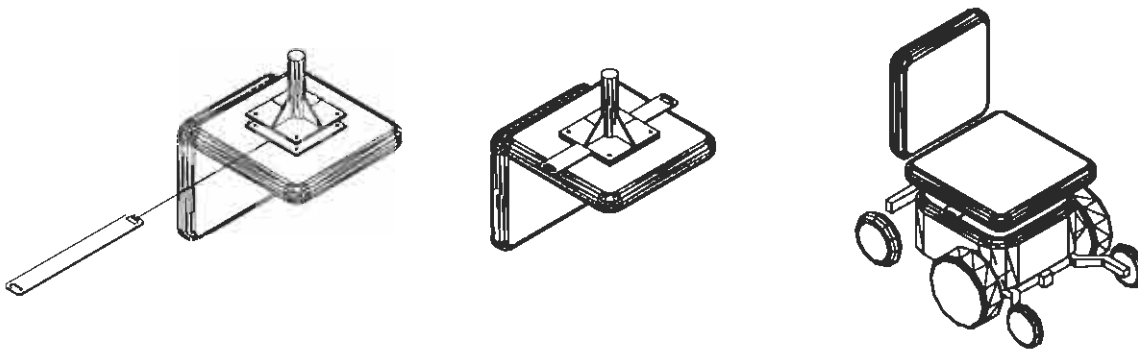

**Anchor U-Bolts:** The U-Bolts are to be used with Power Chairs or Scooters that do not have a center seat post. On this type of chair, the seat is normally attached to a tubular frame. Attach the U-Bolts, two on each side, to the frame as shown below. Make sure that the loop extends to the outside of the chair to allow the strap hooks to be attached by the end user.

Each type of chair will differ slightly and the placement of the U-bolts will differ between different models and manufacturers. Place the Anchor U-Bolts towards the center of the seat if possible. Because of the different types of seats, you may be forced to attach the Anchor U-Bolts more towards the front or rear of the seat, but we recommend attachment as close as possible to the center of the seat.

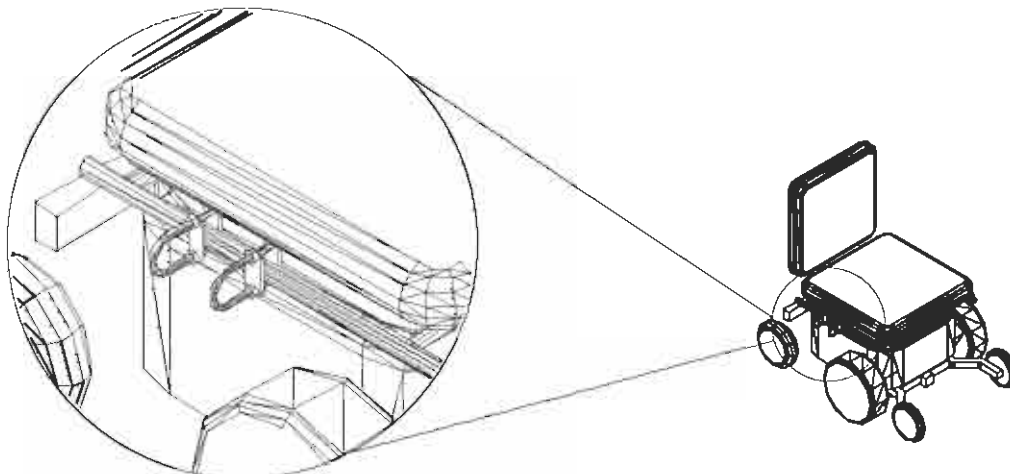

# Installation w/ Removable 3rd Row Seat

# AL600 & AL650

Remove third row seat. If your vehicle does not have a removable third row seat, see the next page for instructions.

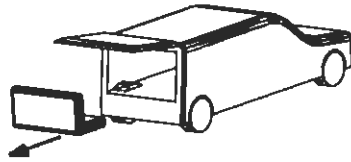

**Installing the Leg Assembly:** Place the leg assembly into the vehicle. Orientate the leg assembly as shown in the drawing to the right. Hook both of the J-Bolts into the third row seat attachment points. Verify that the leg assembly is centered from side to side within the vehicle. Tighten the nuts on the J-bolts until the assembly is firmly attached to the vehicle. At this time the foot plate should be placed in the vehicle near the rear opening. This will support the two rearmost feet of the lift and keep the feet from pressing into the floor pan of the vehicle.

Install the 4 Leveling Pads from the hardware pack at this time. Each Pad will thread into the underside of the base at each corner. Leveling adjustment can be after the lift has been installed.

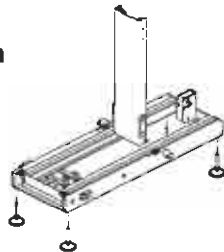

**Placing the lift into the vehicle:** Pick up the lift and place it into the vehicle's cargo area. This operation will require two people to perform. Take care during this operation not to scratch the vehicle's interior. Position the lift such that it will be 6 inches inside of the rear door. Verify this by closing the rear door and inspecting the fit from inside of the vehicle.

**If your vehicle has a lip at the rear door you will need to use the adjustable feet to raise the entire lift so that all of its moving parts will clear the door lip.**

Use a wrench to extend the adjustable feet until the lift's middle stage will clear the door lip and door latch by 0.5".

**Leveling the lift:** The floor in some vehicles is not level. To level the lift start by parking the vehicle on level ground. Use a carpenter's level to verify the lift is level. If it is not, adjust the four feet until the lift is level.

**Attaching the lift into the vehicle:** The leg assembly has two sets of large holes in its upper surface. When installing a Pioneer for use with a scooter, select the holes that will offset the lift to the driver's side of the vehicle. When installing the Pioneer for use with a power chair, select the holes that will offset the lift to the passenger's side of the vehicle. Insert both hold down rods into the holes in the Leg Assembly. If needed you may slide the hold down brackets along the lift's body so that the hold down rods line up with the holes in the top of the leg assembly. Crossbolt the hold down rods in place with the supplied hardware. Tighten the 5/8" nuts on the hold down rods, until the lift is attached securely to the vehicle.

**Caution:** Do not remove the hold down brackets and reattach them on the opposite side of the Platform Keeper.

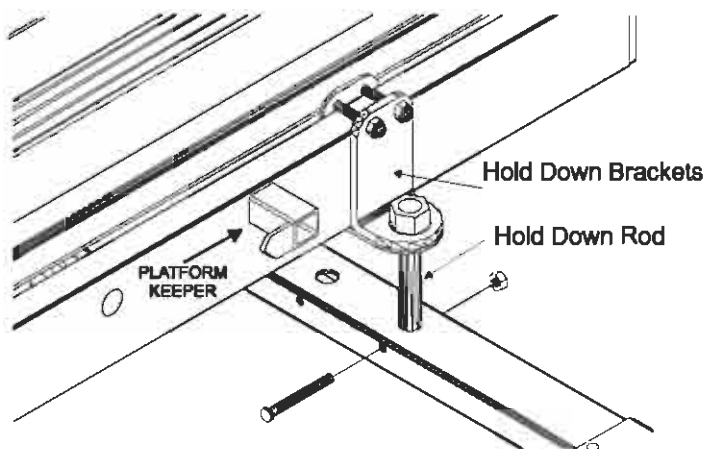
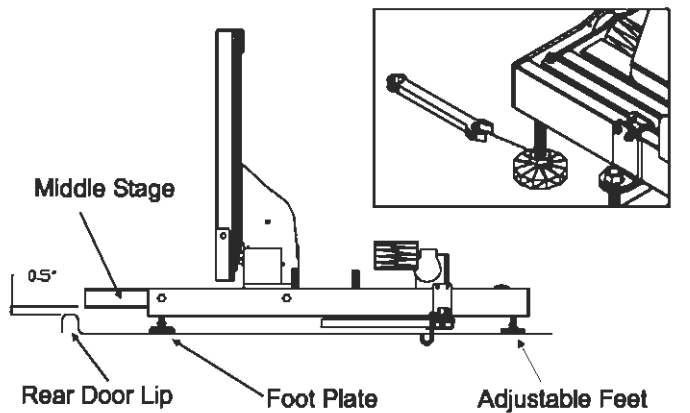
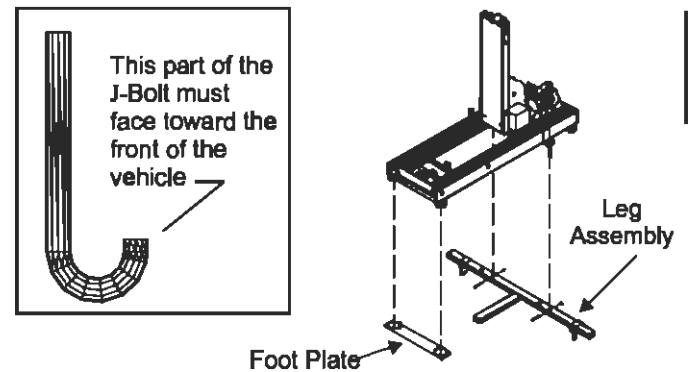
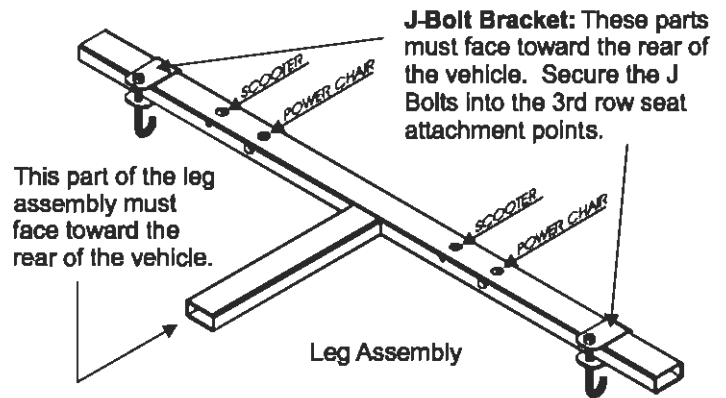



# AL600 & AL650

# Installation w/out Removable 3rd Row Seat

## Leg Assembly

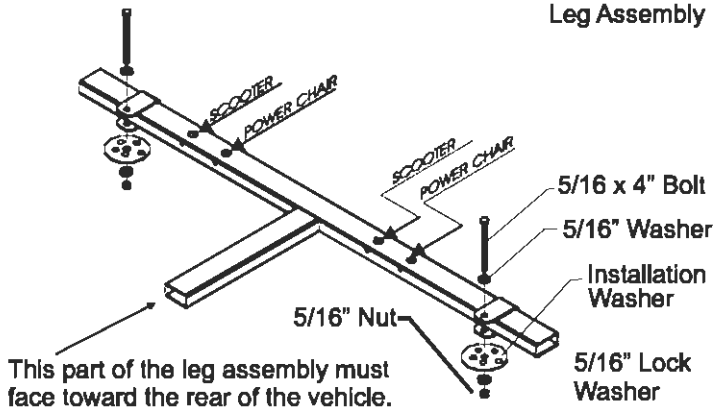

### Installing the Leg Assembly:

Place the leg assembly into the vehicle. Orientate the leg assembly as shown in the drawing to the right. Also place the foot plate in the vehicle near the rear opening. This will support the two rearmost feet of the lift and keep the feet from pressing into the floor pan of the vehicle.

Install the 4 Leveling Pads from the hardware pack at this time. Each Pad will thread into the underside of the base at each corner. Leveling adjustment can be after the lift has been installed.

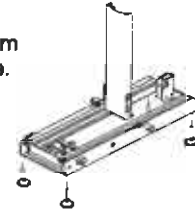

Pickup the lift and place it into the vehicle's cargo area. This operation will require two people to perform. Take care during this operation not to scratch the vehicle's interior. Position the lift such that it will be 6 inches inside of the rear door. Verify this by closing the rear door and inspecting the fit from inside of the vehicle.

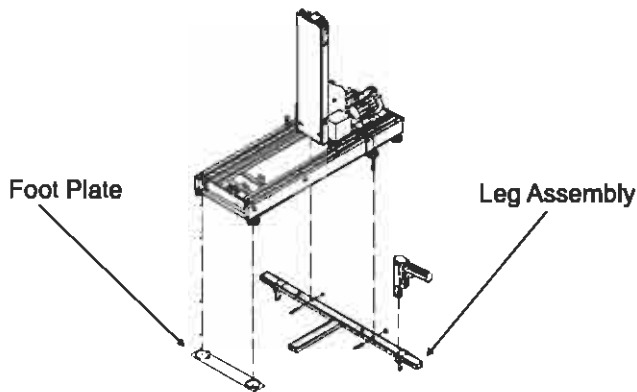

Position the leg assembly so that it is located in line with the hold down rods on either side of the lift. (See the picture at the bottom of this page.) If needed you may slide the hold down brackets along the lift's body.

Remove the J-bolts from the leg assembly and replace them with the hardware shown in the drawing to the right. Use an 11/32" drill bit to drill holes through the vehicle floor for attaching the 5/16" bolts.

**Caution!** Inspect the underside of the vehicle for obstacles before drilling any holes. Avoid the vehicle's wiring, fuel lines, fuel tanks, spare tires, seat cushions, etc.

From beneath the vehicle attach the installation washers, 5/16" lock washers and 5/16" nuts. Verify that the leg assembly is centered from side to side within the vehicle. Tighten the nuts on the 5/16" bolts until the assembly is firmly attached to the vehicle.

If the vehicle has a lip at the rear door you will need to use the adjustable feet to raise the entire lift so that all of its moving parts will clear the door lip.

Use a wrench to extend the adjustable feet until the lift's middle stage will clear the door lip and door latch by 0.5".

**Leveling the lift:** The floor in some vehicles is not level. To level the lift start by parking the vehicle on level ground. Use a carpenter's level to verify the lift is level. If it is not, adjust the four feet until the lift is level.

**Attaching the lift into the vehicle:** The leg assembly has two sets of large holes in its upper surface. When installing a Pioneer for use with a scooter, select the holes that will offset the lift to the driver's side of the vehicle. When installing the Pioneer for use with a power chair, select the holes that will offset the lift to the passenger's side of the vehicle. Insert both hold down rods into the holes in the Leg Assembly. Crossbolt the hold down rods in place with the supplied hardware. Tighten the 5/8" nuts on the hold down rods, until the lift is attached securely to the vehicle.

**Caution:** Do not remove the hold down brackets and reattach them on the opposite side of the Platform Keeper.

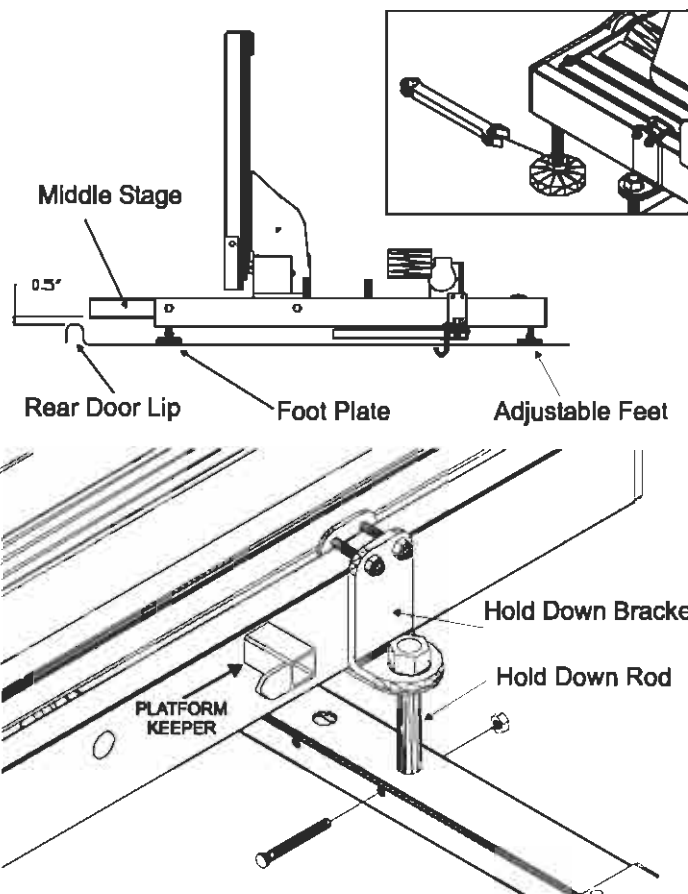

**Connecting the Electrical Components:** Plug the hand control into the vehicle wiring harness. Then plug the other end into the electrical harness located on the rear of the lift.

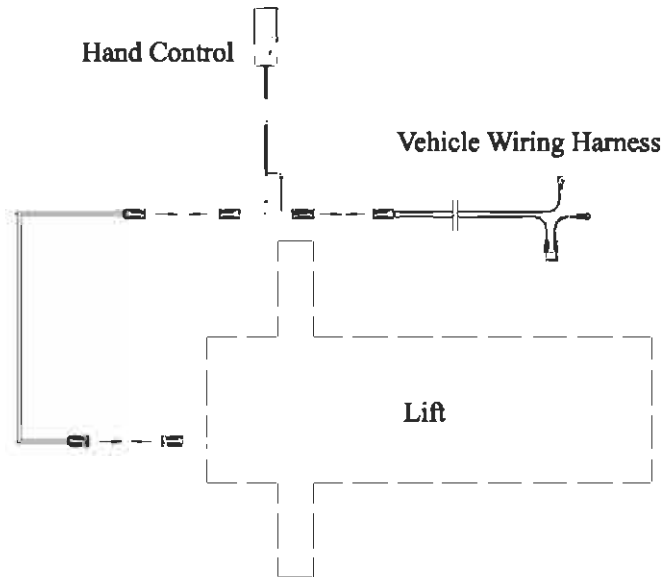

**Extending the Lift:** Push the down button on the hand control to extend the lift in the horizontal direction.

**CAUTION:** Watch the lift as it extends. Make sure the moving components of the lift do not rub against the vehicle's interior, door lip, or door latch. You may need to stop and adjust the lift's height, by repeating the steps on the installation page.

When the lift is fully extended, it will start to run down in the vertical direction. At this point stop the lift. If you are using the Pioneer to lift power chairs the platform is now ready to be installed. If you are using the Pioneer to transport scooters, follow the instructions on the next page for how to modify the platform for use with a Scooter.

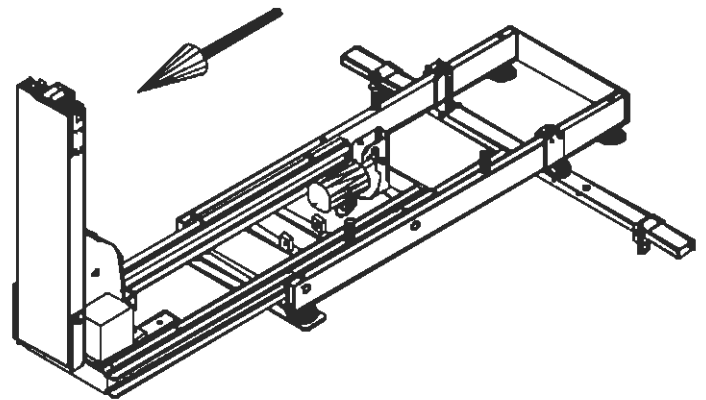

## Installing the Platform for use with a Power Chair:

Bolt the platform to the lift assembly as shown to the right using the supplied 1/2" diameter and 5/16" diameter hex bolts.

If loading a Scooter, refer to next page for instruction on attaching front wheel plate to platform.

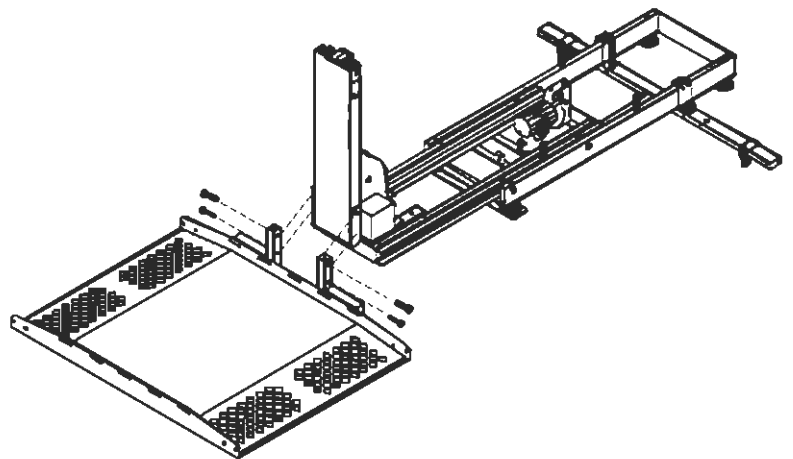

## Modifying the Platform for use with Scooters:

Contained in the lift box will be the front wheel scooter adapter. This must be attached to the platform for all scooter applications. Attach the front wheel scooter adapter using the provided hardware to the platform end plates on the passenger's side of the platform.

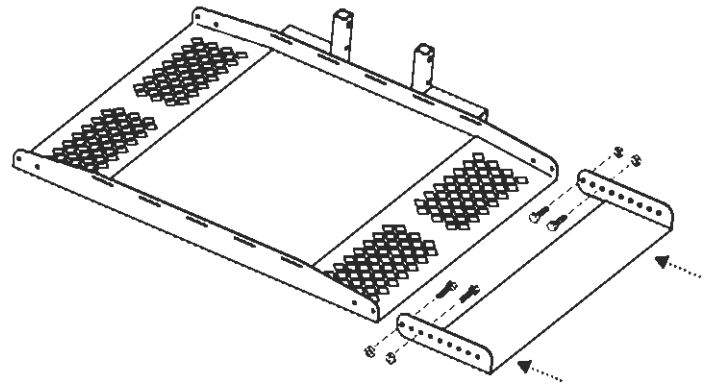

Remove the two restraints, add the front wheel cradle, and reassemble the restraints in the same holes from which they were removed.

## Installing the Platform for use with a Power Chair:

Bolt the platform to the lift assembly as shown to the right using the supplied 1/2" diameter and 5/16" diameter hex bolts.

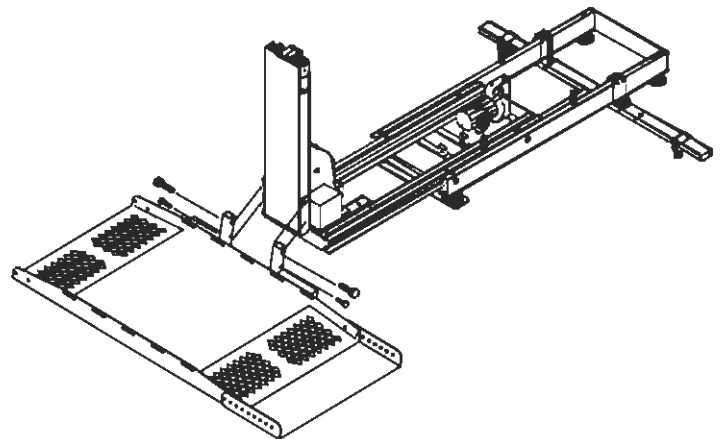

Remove 2nd Row Seating

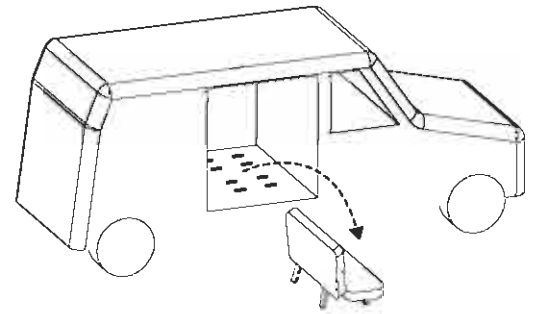

- 1) Place Leg Assemblies in vehicle and secure to seat attachments points left behind from seat. If attachment points are unavailable, drill in convenient locations, avoiding gas tank, fuel lines, A/C lines etc...and substitute J-hooks for 5/16 bolts included in hardware pack. Leave loose to for adjustment purposes.

If J-Hooks are used, cut off excess threads to avoid interference

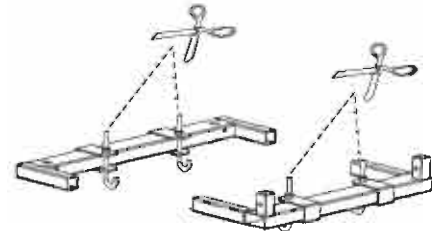

- 2) With assistance, place lift body into leg assemblies aligning holes in all-thread attached to lift body, and cross hole in Leg Assembly (marked "A")

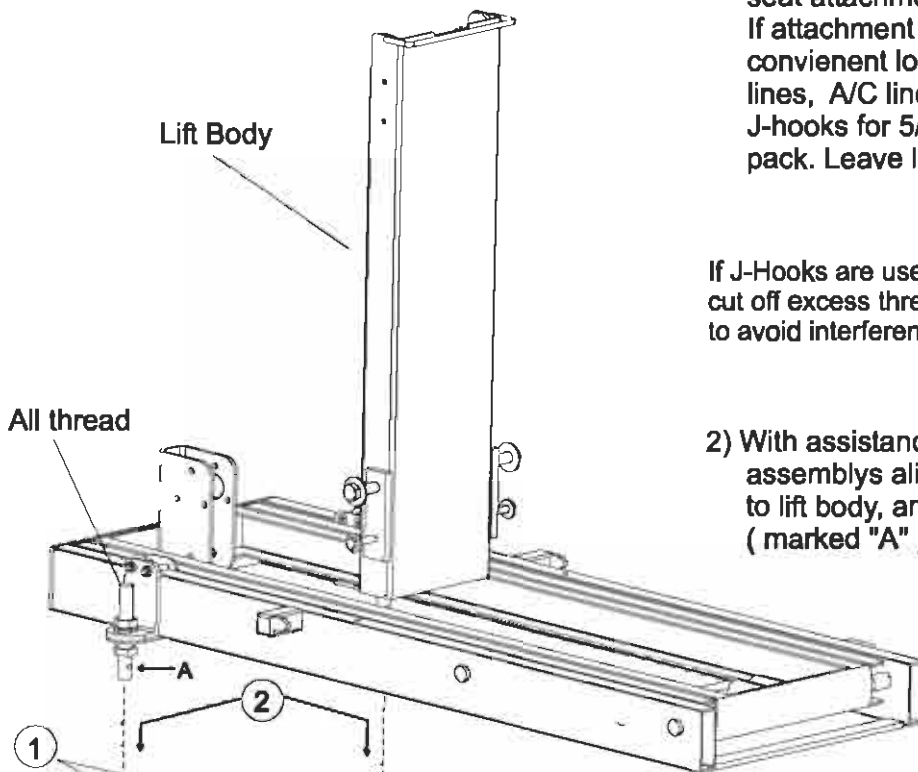

- 3) Secure All Thread to Leg Assembly by cross-bolting 1/4" screw thru and tighten with nut to other side as shown.

- 4) Do not tighten side set screws just yet, as once platform is attached ( next page ) the lift may need to be slid back or forth to clear side door.

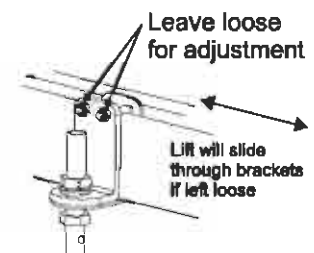
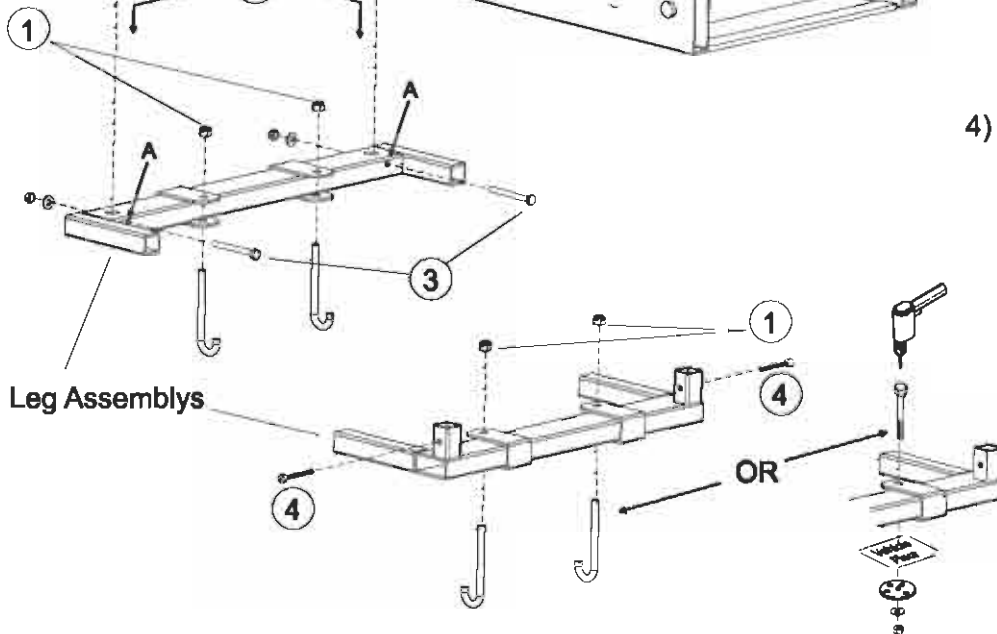

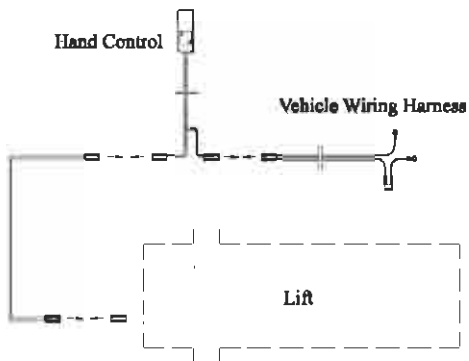

Plug Hand Control into Vehicle Harness and into Lift. To ease attachment of Platform, run the lift forward ( down ) until Platform can be easily mounted.

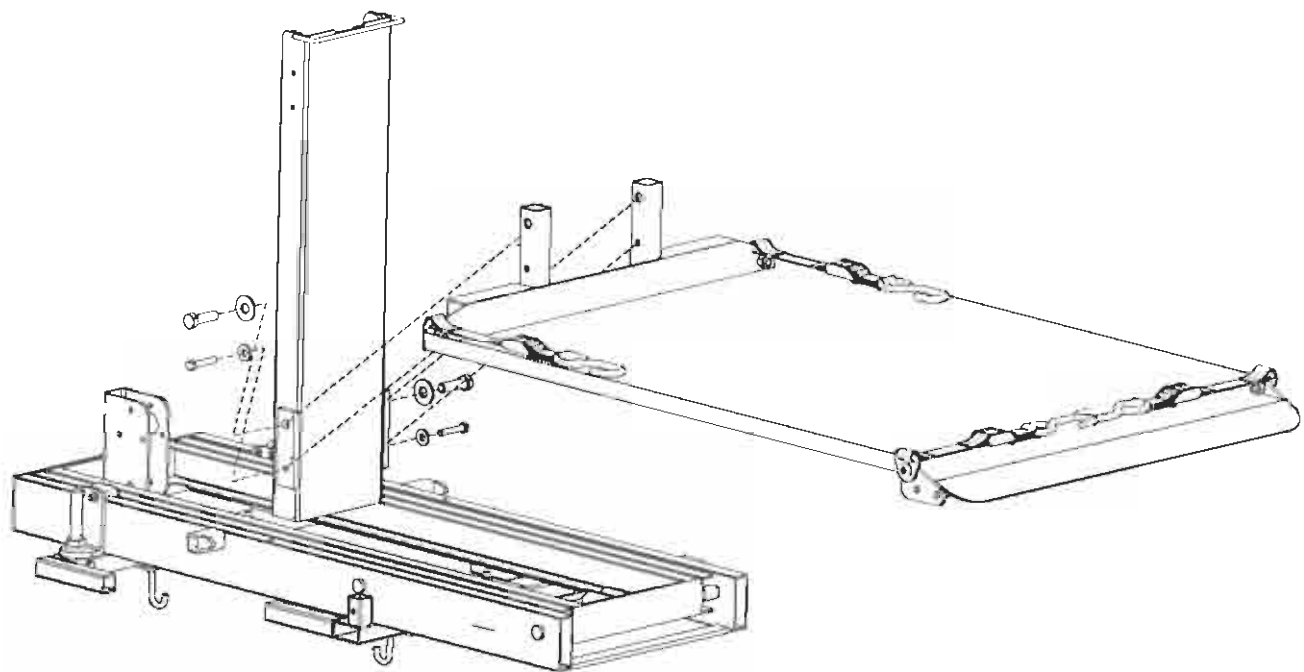

Attach Platform to Lift using the attached hardware ( 2-1/2" dia bolts, and 2-5/16" dia bolts)

Check clearance of side door from van to be sure platform clears. Once Lift is in desired position, tighten all fasteners.

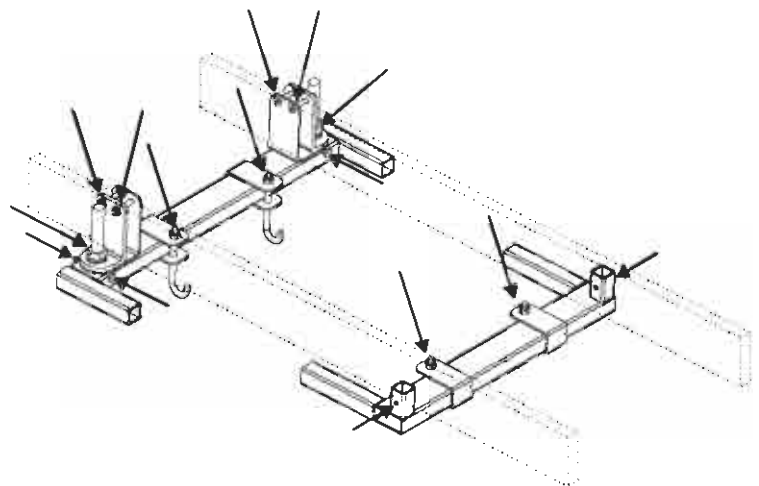

# Loading a Power Chair

AL600

**Parking the Chair on the Platform:** Before loading the power chair, verify that the platform has been lowered all the way to the ground. Set your chair's speed control at a slow speed so that you may maneuver comfortably onto the platform. You may drive onto the platform from either side. Park the chair such that it is centered on the platform.

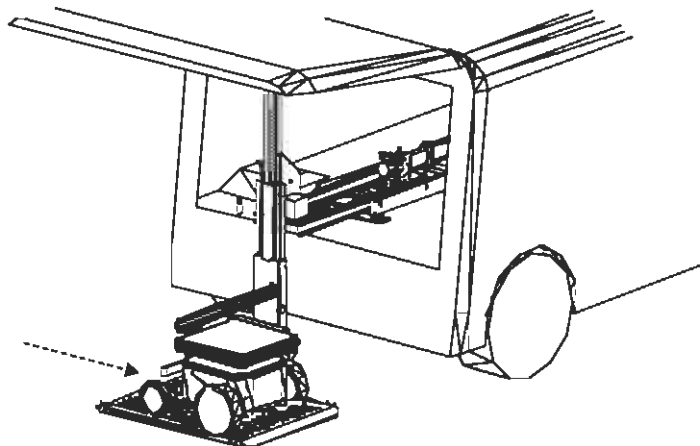

**Securing the Chair to the Platform:** The Pioneer platform has a restraint attached to each corner of the platform. Each restraint has a hook at the end. Place each hook in either the anchor plate slot, or in each U-bolt. Pull the loose end of each restraint tight. To release, simply press the release tab, and remove the hooks.

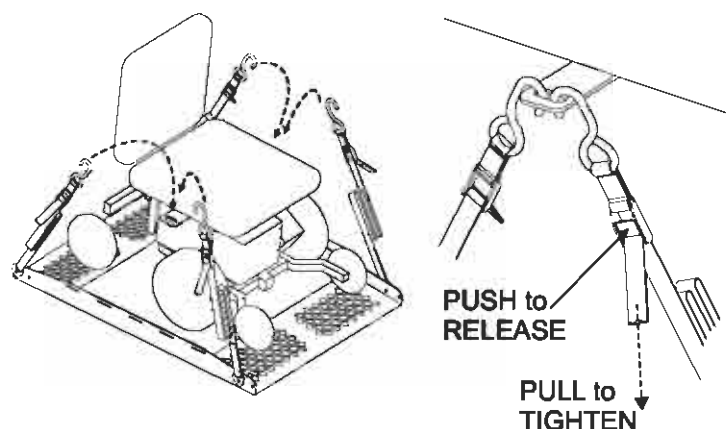

**Folding Seat Backs:** If your chair has a folding seat back you may wish to fold it to the down position. This will allow you more clearance when loading the chair into the vehicle. Depending on the size of your chair, you may need to remove the head rest to provide for sufficient clearance.

**Raising the Chair:** Before raising, verify that the chair is secured to the platform. While holding the hand control stand to the side and away from the lift. Press the up button. The lift will raise and retract into the vehicle. The lift is retracted fully when the platform is fully inside of the vehicle and the lift's motion stops. At this point release the button. Secure the hand control by placing it on the hook and loop patch attached to the lift. Close the rear door carefully taking notice of any baskets, backpacks or additional items attached to the chair that maybe hit by the door.

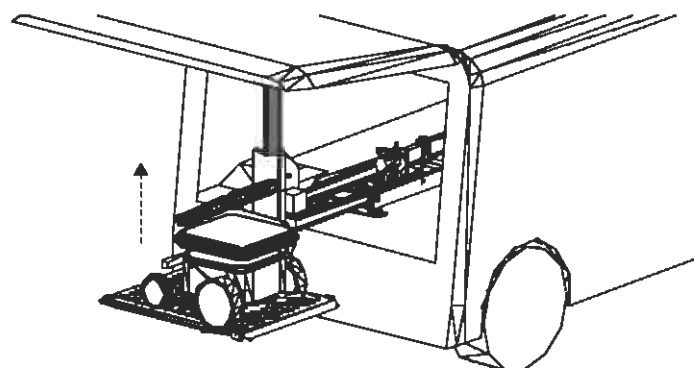

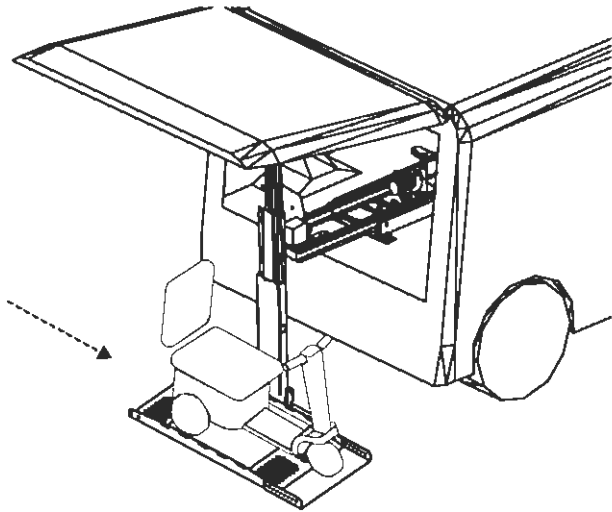

**Parking the Scooter on the Platform:** Before loading the scooter, verify that the platform has been lowered all the way to the ground. Set your scooter's speed control at a slow speed so that you may maneuver comfortably onto the platform. You must drive onto the platform from the driver's side of the vehicle. Park the scooter such that the front wheel(s) is(are) on top of the front wheel scooter adapter.

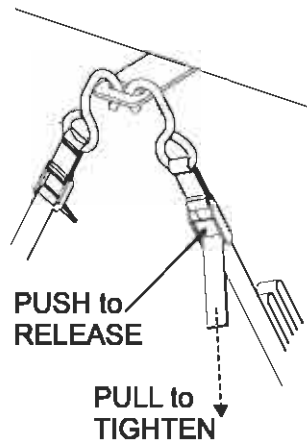
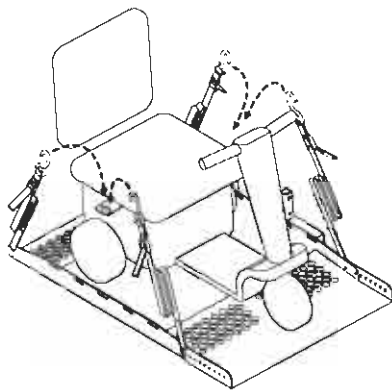

**Securing the Scooter to the Platform:** The Pioneer platform has a restraint attached to each corner of the platform. Each restraint has a hook at the end. Place each hook in either the anchor plate slot, or in each U-bolt. Pull the loose end of each restraint tight. To release, simply press the release tab, and remove the hooks.

**Folding Seat Backs:** If your scooter has a folding seat back you may wish to fold it to the down position. This will allow you more clearance when loading the scooter into the vehicle. Depending on the size of your scooter, you may need to remove the head rest to provide sufficient clearance.

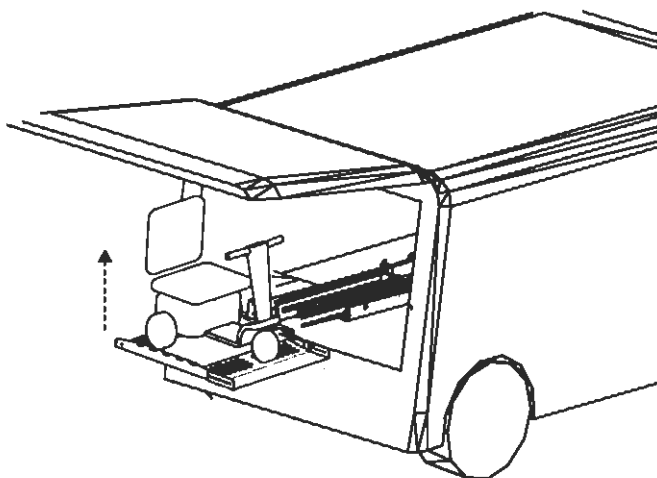

**Stowing the Scooter:** While holding the hand control, stand to the side and away from the lift. Press the up button again. The lift will raise and retract into the vehicle. The lift is retracted fully when the platform is inside of the vehicle and the lift's motion stops. At this point release the button. Secure the hand control by placing it on the hook and loop patch attached to the lift. Close the rear door carefully taking notice of any baskets, backpacks or additional items attached to the scooter that may be hit by the door.

# Loading a Power Chair

# AL650

**Parking the Chair on the Platform:** Before loading the power chair, verify that the platform has been lowered all the way to the ground. Set your chair's speed control at a slow speed so that you may maneuver comfortably onto the platform. Drive the chair onto the platform into the opening of the docking station.

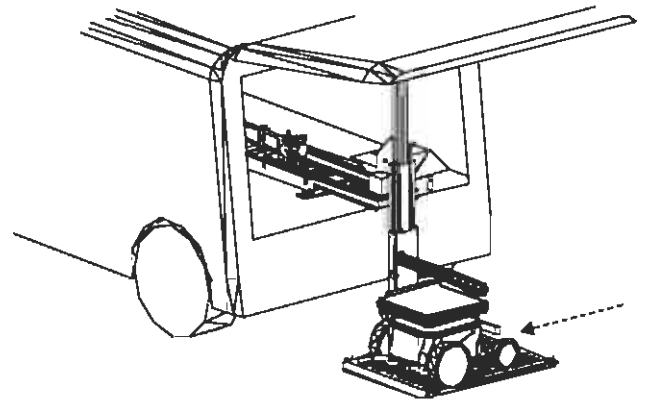

## THREE WAYS TO VERIFY YOUR CHAIR IS SUCCESSFULLY LOCKED DOWN

### ✓ 1) AUDIBLE "CLICK or POP" SOUND

As the chair enters the locking device, it should be driven forward until an audible pop or clicking sound is heard. This sound is the locking device setting itself around the chair's docking device pin.

### ✓ 2) VISUAL INDICATOR

The yellow indicator will extend and stay extended when the chair is successfully locked in place.

### ✓ 3) REVERSE TEST

Attempt to back the chair off the platform. The chair will NOT move in any direction when successfully locked.

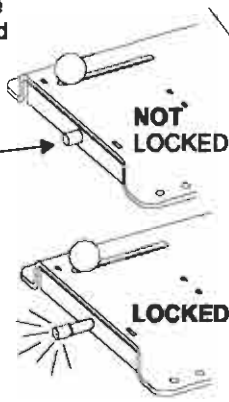

Verify Chair is locked onto Platform

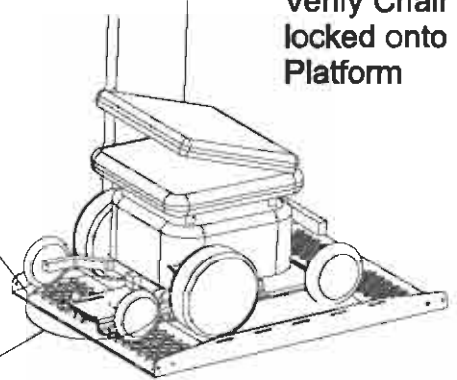

**Raising the Chair:** Before raising, verify that the chair is secured to the platform. While holding the hand control stand to the side and away from the lift. Press the up button. The lift will raise and retract into the vehicle. The lift is retracted fully when the platform is fully inside of the vehicle and the lift's motion stops. At this point release the button. Secure the hand control by placing it on the hook and loop patch attached to the lift. Close the rear door carefully taking notice of any baskets, backpacks or additional items attached to the chair that maybe hit by the door.

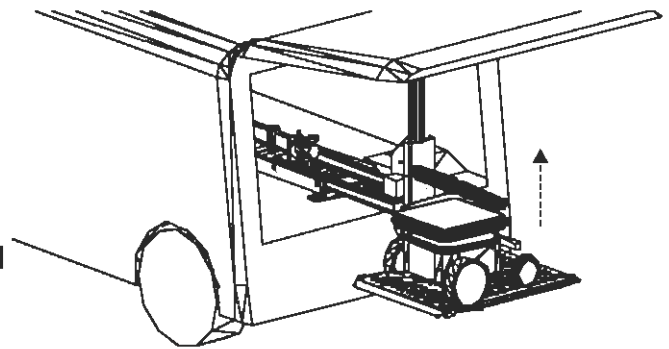

**To Unload Chair:** Lower Platform to the ground. Push knob as shown to the right. Drive off chair in reverse. The Docking Station will automatically reset itself to accept the next time the chair is loaded.

TO RELEASE CHAIR  
Slide knob this direction

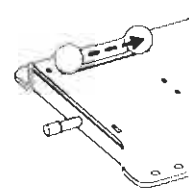

**NOTE:** During transport, vibration may cause the chair to tighten itself in the locking device, making the release knob difficult to slide. To overcome this, simply drive the chair forward a bit. This will take pressure off the knob, allowing an easier release.



# AL690

## Loading a Power Chair or Micro Scooter

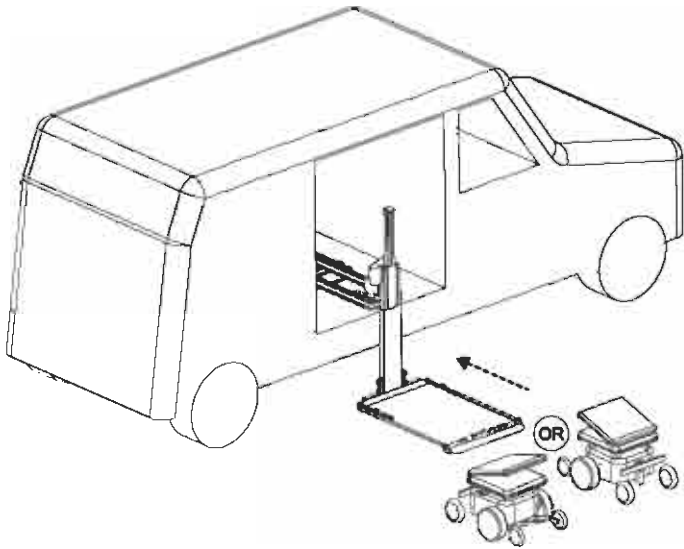

**Parking the Chair on the Platform:** Before loading the power chair, verify that the platform has been lowered all the way to the ground. Set your chair's speed control at a slow speed so that you may maneuver comfortably onto the platform. Either back the chair onto the platform, or drive forward depending on the chair's weight displacement. The heaviest portion of the chair needs to be closest to the lifting tower.

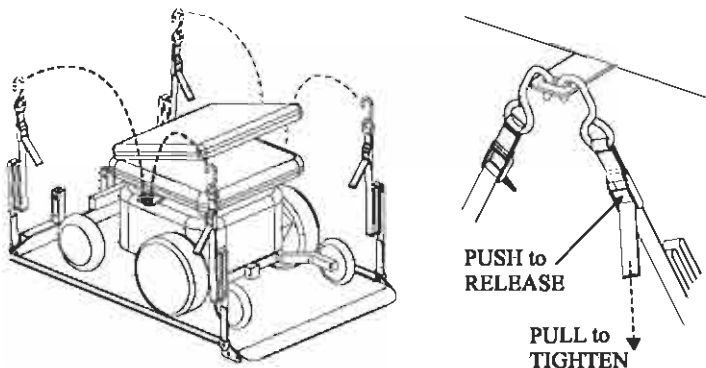

**Securing the Chair to the Platform:** The Pioneer platform has a restraint attached to each corner of the platform. Each restraint has a hook at the end. Place each hook in either the anchor plate slot, or in each U-bolt. Pull the loose end of each restraint tight. To release, simply press the release tab, and remove the hooks.

**Folding Seat Backs:** If your chair has a folding seat back you may wish to fold it to the down position. This will allow you more clearance when loading the chair into the vehicle. Depending on the size of your chair, you may need to remove the head rest to provide for sufficient clearance.

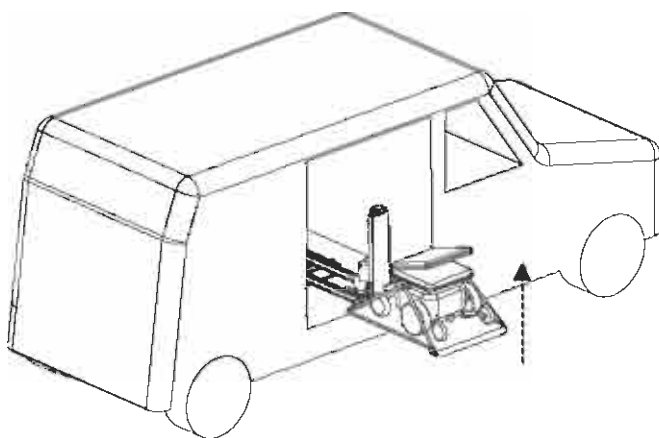

**Raising the Chair:** Before raising, verify that the chair is secured to the platform. While holding the hand control stand to the side and away from the lift. Press the up button. The lift will raise and retract into the vehicle. The lift is retracted fully when the platform is fully inside of the vehicle and the lift's motion stops. At this point release the button. Secure the hand control by placing it on the hook and loop patch attached to the lift. Close the side door carefully taking notice of any baskets, backpacks or additional items attached to the chair that may be hit by the door.

# Safety and Maintenance

## SAFETY:

- **Caution:** Do not operate this lift until your dealer has satisfactorily instructed you in the proper operation of the lift.
- Your Harmar lift has been engineered and designed for years of trouble free use. Although, with everyday use, some parts may become loose or worn. **IMPORTANT!** Check regularly for any worn, loose or damaged parts of your lift. **If anything is observed, DO NOT USE THE LIFT!** Contact your dealer or installer of the lift for repairs to be made. **Failure to act may cause severe injury!**
- Your Harmar lift should only be used for the loading and unloading of scooters and power wheelchairs for which it is designed. **DO NOT** add to or modify any part of the lift system without first contacting the manufacturer of the lift. Any modifications may void any warranties as well as effect the structural integrity of the lift.
- Always make sure the vehicle's parking brake is firmly set before operating the lift.
- **Caution:** When using the lift, keep your hands and feet from under the scooter or power chair as it is being loaded or unloaded.
- **Warning:** This lift is not meant for human transport. The mobility device and platform must be unoccupied before operating the lift.

## MAINTENANCE:

The Harmar lift has been designed to be as trouble free as possible for the owner. But, as with any mechanical device, regular care should be given while owning and using this device. Maintenance should be performed regularly.

- We recommend that dealers schedule a preventative maintenance inspection at least once a year on motors, lift frame, wiring harness and all moving parts of the lift.
- Check for paint chips and touch up any bare metal with a good gloss black enamel or lacquer to inhibit rust. This may be necessary more frequently when subjected to salt air or road salt.

## TROUBLESHOOTING:

**PROBLEM:** The lift will not operate or operates slowly.

### **Possible Causes:**

**Bad Connection** - Verify the vehicle wiring harness is tightly attached to the battery and that there is no build up on the terminals.

**Battery** - Check to see if the battery needs to be replaced or if the terminals are corroded. Clean the terminals if any corrosion is present. 12 volts should be present at the lifting motors from the vehicles battery. This can be tested with a voltage meter.

**PROBLEM:** Intermittent power to the lift. The lift will operate for a short period of time and quit. At a later time it will start working again.

### **Possible Causes:**

**Circuit Breaker** - Although the breaker resets itself automatically, it may be malfunctioning and need to be replaced. Check for power at the lift with a test lamp.

**Bad Connection** - Verify the vehicle wiring harness is tightly attached to the battery and that there is no build upon the terminals.

**Hand Control** - Test by bypassing the hand control. Do this for only a second or two. The lift, vehicle, scooter or chair may be damaged if continuous power is left supplied to the unit.

**PROBLEM:** Platform will not sit level on the ground.

### **Possible Causes:**

**Terrain** - Verify that the vehicle is parked on flat level ground.

**Orientation of the lift's base** - Adjust the lift's four feet until the platform sits level on the ground.

# NOTES

A large, empty white rectangular area with a thin black border, intended for taking notes. The top edge of this area is curved, following the shape of the black header above it.