

**ActiveCare**  
Medical

866.621.4933  
[activecaremed.com](http://activecaremed.com)



Medalist™  
Power Wheelchair  
Owner's Manual

# Table of Contents



<b>1. Preface</b> .....	<b>2</b>
<b>2. Safety Notices</b> .....	<b>3</b>
<b>3. EMI</b> .....	<b>4</b>
Electromagnetic Interference (EMI) From Radio Wave Sources .....	4
Powered Wheelchair Electromagnetic Interference (EMI) .....	5
<b>4. Parts</b> .....	<b>6</b>
<b>5. Assembly</b> .....	<b>7</b>
<b>6. Folding &amp; Disassembly</b> .....	<b>10</b>
<b>7. Operation</b> .....	<b>13</b>
General Information .....	13
Controller.....	13
Security Functions.....	14
<b>8. Charger</b> .....	<b>15</b>
Specifications.....	15
Features .....	15
Operation Instructions.....	15
Usage Environment.....	15
Notes .....	15
<b>9. Inspection &amp; Maintenance</b> .....	<b>17</b>
Battery.....	17
Motor .....	17
Electrical Brakes.....	17
Tires .....	17
<b>10. Troubleshooting</b> .....	<b>18</b>
<b>11. Specifications</b> .....	<b>19</b>
<b>12. Limited Warranty</b> .....	<b>20</b>
Warranty Registration .....	22

# 1. Preface

Please read this owner's manual before using the power wheelchair. Improper use of the power wheelchair could result in harm, injury or traffic accidents.

This owner's manual includes operation instructions for every aspect of the power wheelchair, assembly instructions, as well as instructions for how to deal with possible accidents.

The symbols used in this manual are explained below. Read carefully, especially the parts marked with these symbols:

 <b>Warning</b>	Improper usage could lead to death or serious injury
 <b>Caution</b>	Improper usage could lead to injury and/or damage to your power wheelchair.
 <b>Suggestion</b>	Follow these instructions to keep the status of the power wheelchair working well and ease your operation.

This manual includes the repair and maintenance record chart and warranty. Please keep it in a proper place or on the wheelchair.

If someone else uses the wheelchair, please be sure to give the instruction manual to him or her.

As designs change, some illustrations and pictures in the manual may not correspond to the wheelchair that you purchased. We reserve the right to make design modifications.

The manufacturer disclaims all responsibilities for any personal injury or property damage which may occur as a result of improper or unsafe use of its products.

## 2. SAFETY NOTICES

1. Always fully charge your power chair before operating.
2. Always make sure the power is off when getting in and out of the power chair.
3. Always make sure the clutch levers are engaged (parallel to the wheels) before getting in or out the wheelchair.
4. To prolong the life of the battery, it is suggested you charge the battery after every trip. If you do not drive it for long periods of time, charge it at least once per month.
5. If the battery gauge goes to RED, charge the battery as soon as possible. If the battery is totally discharged, it could be damaged, and/or its life could be shortened.
6. As the battery ages and deteriorates, the battery power will decrease faster.
7. In cold weather, the battery capacity will be less.
8. When you are charging the battery, please make sure that the input-voltage (115V/230V) switch on your charger matches your power source.
9. Avoid unnecessarily moving of the power chair.
10. Please fasten the seat belt, if included, while driving and check the proper position of the anti-tip wheel.
11. Our products function best at temperatures between 32-122° Fahrenheit.
12. Disassembling of controller, motor or charger by end user is prohibited; the dealer will not take any responsibility on these kinds of situations.
13. Prevent the controller, charger and battery from getting wet; this can cause a malfunction.
14. To ensure the user's familiarity with the power chair's operation, the new driver should practice driving in a spacious area, traveling forward, backward, left, right, using the brakes, and going both up and down slopes.
15. Please turn off the power chair when the chair is not in use and before charging the battery.
16. The following areas and conditions can be dangerous and should be avoided; darkness, dim lighting, steep slopes, rain, snow, shoulder of the road, slippery areas, etc.
17. Please do not drive your power chair at night without proper lighting.
18. Please do not lower the footplate to less than 2" (50mm) above the ground, because accidents may occur due to insufficient ground clearance.
19. Keep your feet on the footplate at all times during operation and do not stand on the footplate. If your feet are in the improper position, you can be seriously injured.
20. When the power does not come on, recheck all connections and recharge if necessary.
21. Please check the screws under the joystick periodically and make sure they are not loose, and tighten them if needed.

### 3. EMI

This portion of the manual will provide the user with basic information about the problems with EMI (electromagnetic interference), protective measures can be used to either lessen the possibility of exposure or to minimize the degree of exposure; this section also shows some conditions that unexpected or erratic movements may cause.

**◆ Caution**

It is very important that you read this information regarding the possible effects of electromagnetic interference on your ActiveCare power wheelchair.

#### **ELECTROMAGNETIC INTERFERENCE (EMI) FROM RADIO WAVE SOURCES**

Powered power wheelchairs may be susceptible to electromagnetic interference (EMI), which is interfering electromagnetic energy (EM) emitted from sources such as radio stations, TV stations, amateur radio (HAM) transmitters, two-way radios, and cellular phones. The interference (from radio wave sources) can cause the powered power wheelchair to release its brakes, move by itself, or move in unintended directions. It can also permanently damage the powered power wheelchair's control system. The intensity of the interfering EM energy can be measured in volts per meter (V/m). Each powered power wheelchair can resist EMI up to a certain intensity level. The higher the immunity level the greater the protection. At this time, current technology is capable of achieving at least a 20 V/m immunity level, which would provide useful protection from the more common sources of radiated EMI. This powered power wheelchair model as shipped, with no further modification, has an immunity level of 20 V/m without any accessories.

There are a number of sources of relatively intense electromagnetic fields in the everyday environment. Some of these sources are obvious and easy to avoid. Others are not apparent and exposure is unavoidable. However, we believe that by following the warning listed below, your risk to EMI will be minimized.

The sources of radiated EMI can be broadly classified into three types:

1. Hand-held portable transceivers (transmitter-receivers with the antenna mounted directly on the transmitting unit). Examples include: citizens band (CB) or hand held radios, (security, fire, and police transceivers), cellular telephones and other personal communication devices.

*NOTE: Some cellular telephones transmit a signal while they are ON but not being used.*

2. Medium-range mobile transceivers, such as those used in police cars, fire trucks, ambulances and taxis usually have the antenna mounted on the outside of the power wheelchair.
3. Long-range transmitters and transceivers, such as commercial broadcast transmitters (radio and TV broadcast antenna towers) and amateur (HAM) radios.

*NOTE: Other types of hand-held devices, such as cordless phones, laptop computers, AM/FM radios, TV sets, CD player, and cassette players, and small appliances, such as electric shavers and hair dryers, are not likely to cause EMI problems to your powered power wheelchair.*

## **POWERED WHEELCHAIR ELECTROMAGNETIC INTERFERENCE (EMI)**

EM energy rapidly becomes more intense as one moves closer to a transmitting antenna (source). The EM fields from hand-held radio wave sources (transceivers) are of special concern. It is possible to unintentionally bring high levels of EM energy very close to the powered power wheelchair's control system while using these devices; this can affect your power wheelchairs movement and braking. Therefore, the warnings listed below are recommended to prevent possible interference with the control system of a powered power wheelchair.

### **⊘ Warning!**

Electromagnetic interference (EMI) from sources such as radio and TV stations, amateur radio (HAM) transmitters, two-way radios, and cellular phones can affect motorized power wheelchairs. Following the warnings listed below should reduce the chance of unintended brake release or powered power wheelchair movement which could result in serious injuries.

1. Do not operate hand-held transceivers-receivers, such as citizens band (CB) radios, or turn ON personal communication devices, such as cellular phones, while the powered power wheelchair is turned ON.
2. Be aware of nearby transmitters, such as radio or TV stations, and try to avoid getting close to them.
3. If unintended movement or brake release occurs, turn the powered power wheelchair OFF as soon as it is safe.
4. Be aware that adding accessories or components, or modifying the powered power wheelchair, may make it more susceptible to EMI.
5. Report all incidents of unintended movement or brake release to the power wheelchair manufacturer, and note whether there were sources of EMI nearby.

## 4. Parts

### Medalist

1. Headrest
2. Joystick
3. Controller
4. Seat
5. Front Caster
6. Footplate
7. Backrest
8. Armrest
9. Shroud
10. Rear Wheel

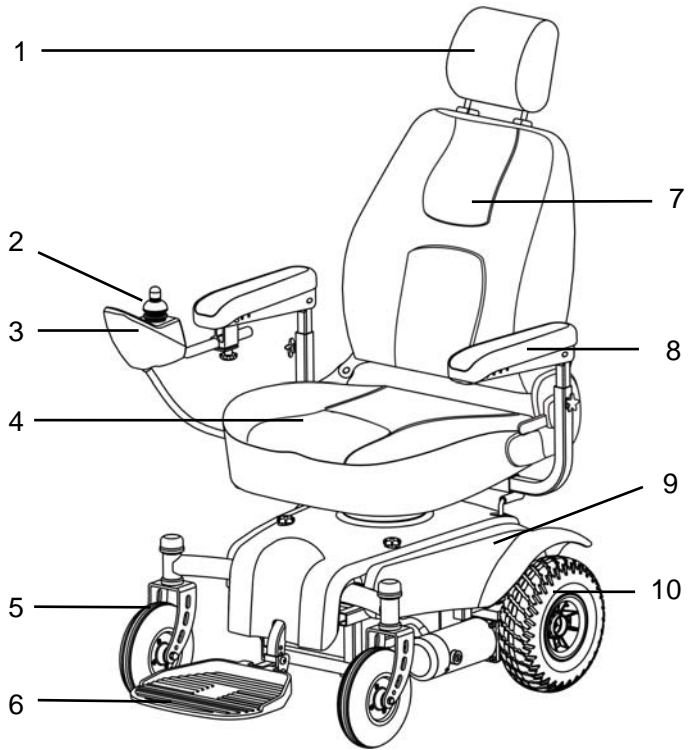

11. Rear Bag
12. Anti-tipper

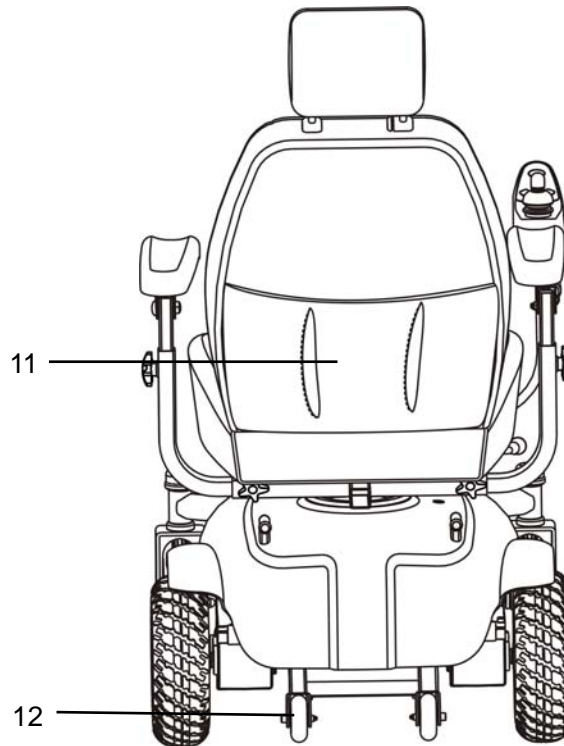

## 5. ASSEMBLY

1. Place both batteries on the frame separated by the middle seat pedestal.

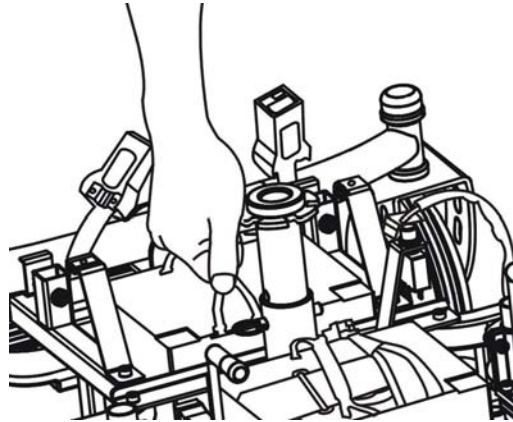

2. Fasten batteries with safety straps.

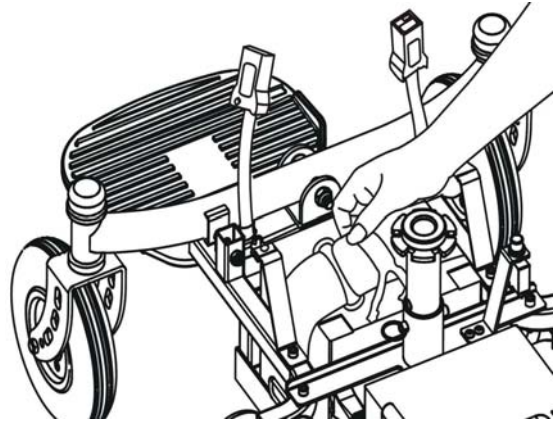

3. From the main cable, there are five connectors. Two connectors are for batteries; two connectors are for the motors and one to the controller.

Connect both battery connectors with the main cable.

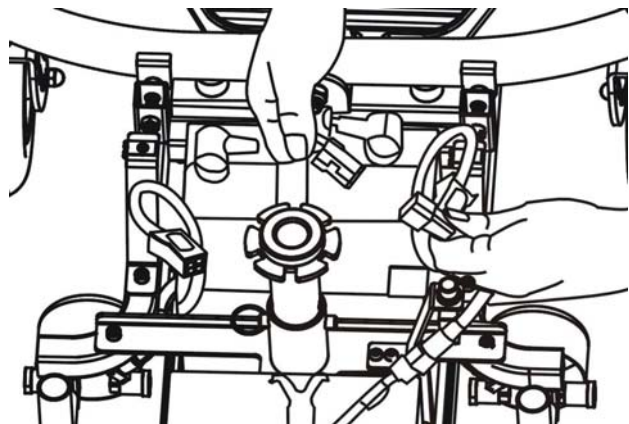

4. Let the cable pass through the hole of shroud.

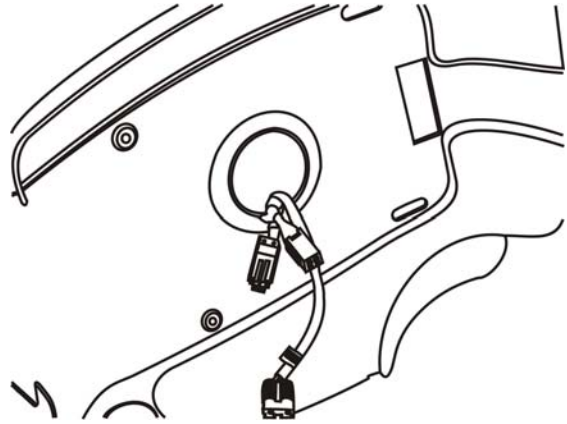

5. Connect both motor connectors with the main cable. Left connector to Left one, right connector to right one. (Left/Right indications are labeled on the wires).

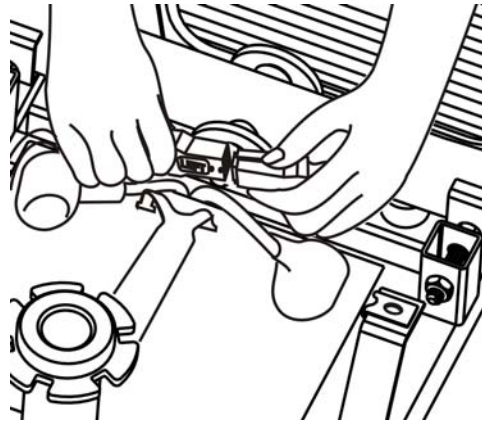

6. The shroud should also slide through the clutch levers—which should be positioned in engaged mode—and secure the shroud to the body frame. (Parallel to the wheels)

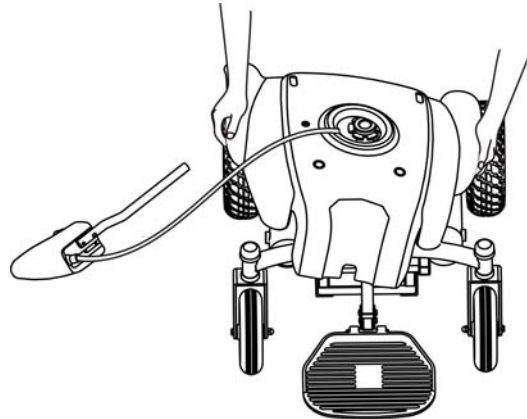

7. Lift the seat and pull the swivel lever up at the same time. Slide the bottom of the seat into the seat pedestal.

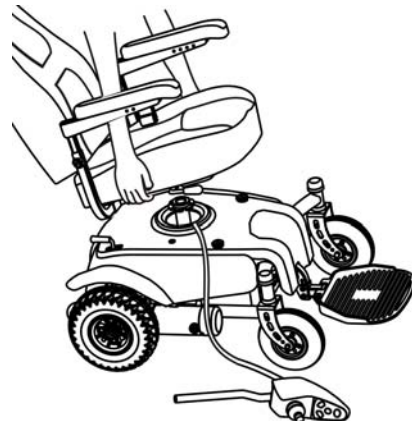

8. Swivel the seat and push down on the seat until it locks in place.

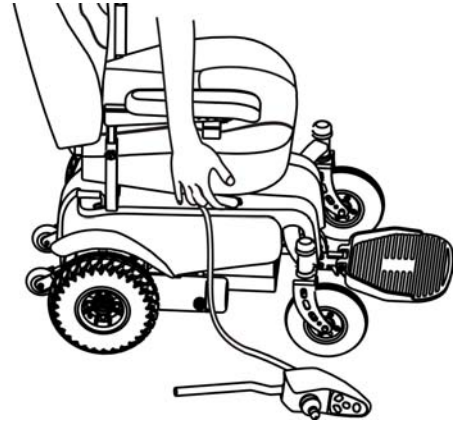

9. Take the controller (round tube) and insert it into the tube under the armrest.

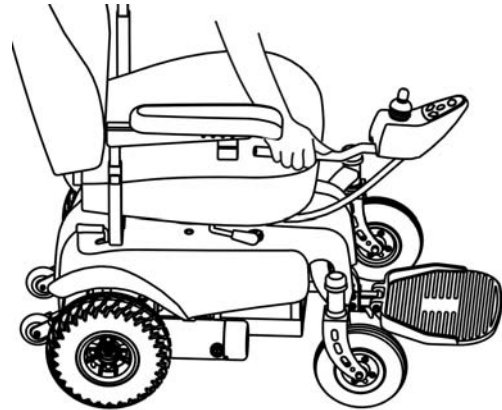

10. Rotate the knob to secure the controller.

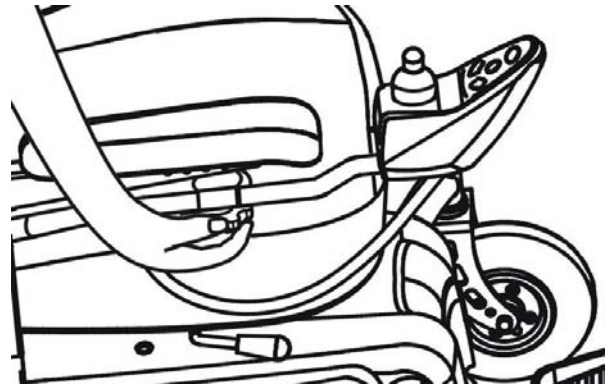

11. Press the power button. The battery gauge will turn on. The power system is now standing by.

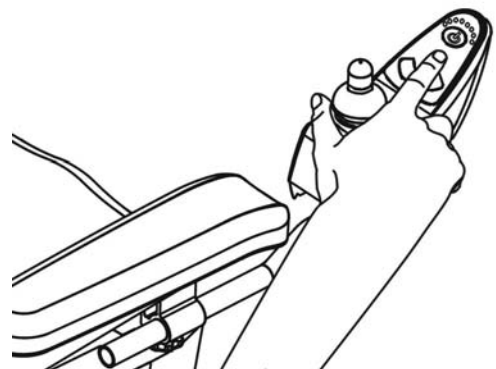

## 6. FOLDING AND DISASSEMBLY

1. Turn off the power (press the power button again); the battery gauge will turn off.

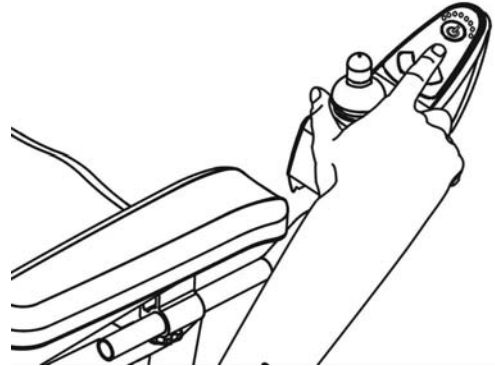

2. Make sure that the motor clutch levers are positioned in engaged mode (Parallel to the wheels).

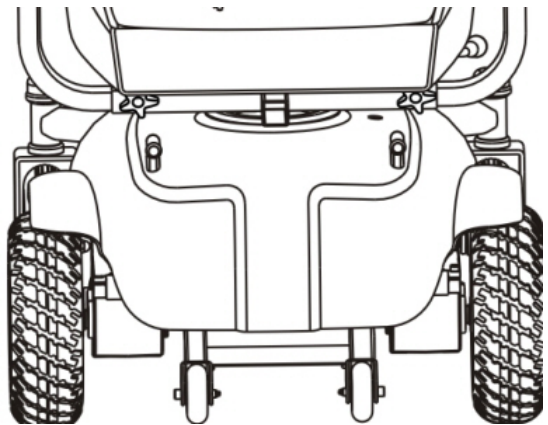

3. Rotate the knob to loosen the tube of the controller.

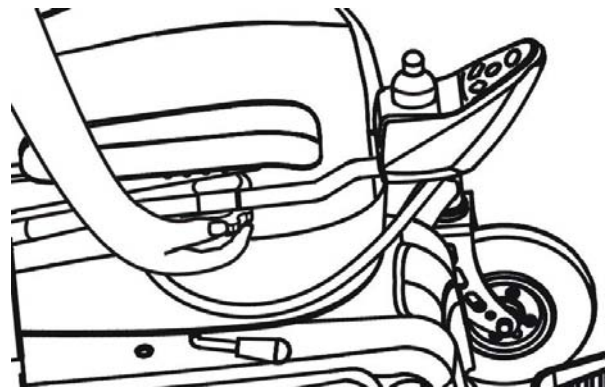

4. Take off the round tube with controller.

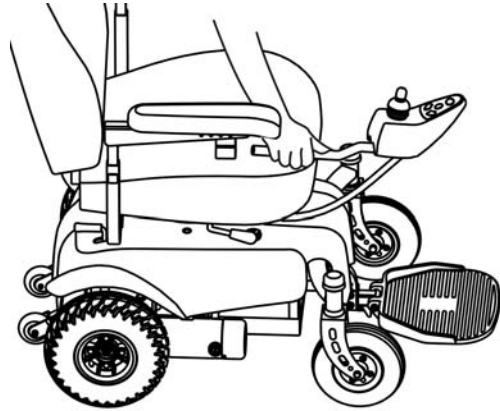

5. Pull the swivel lever up to unlock it and rotate the seat to the position where you can pull the seat up.

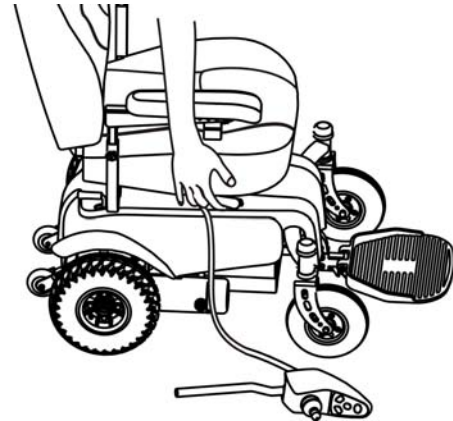

6. Lift the shroud straight up.

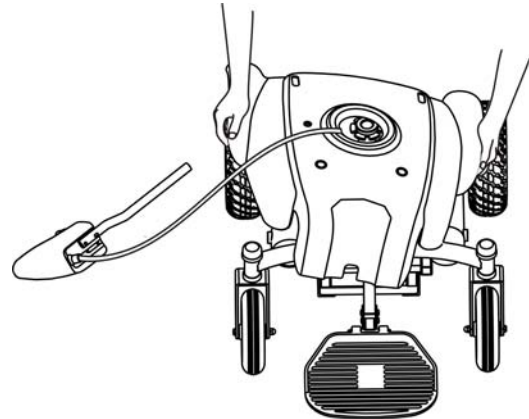

7. Disconnect the cable to the controller from the hole in the shroud.

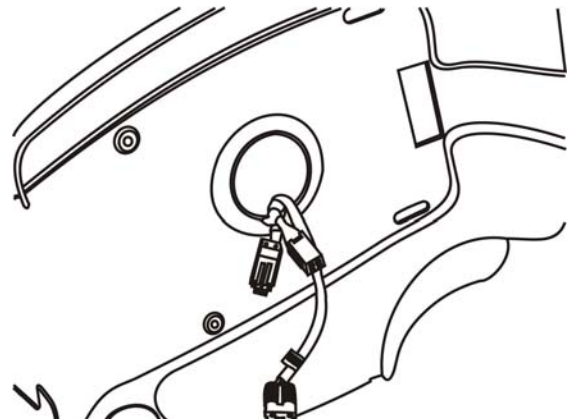

8. Disconnect both motor connectors with the main cable and the power cable.

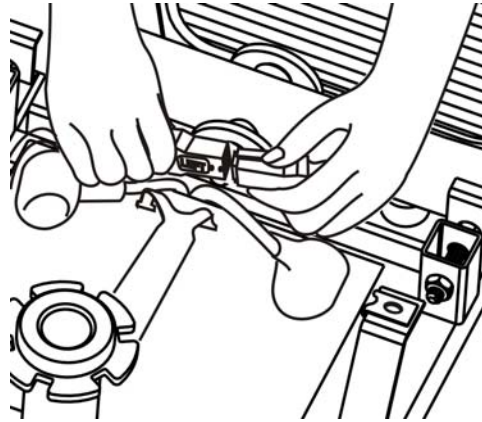

9. Unplug battery connectors.

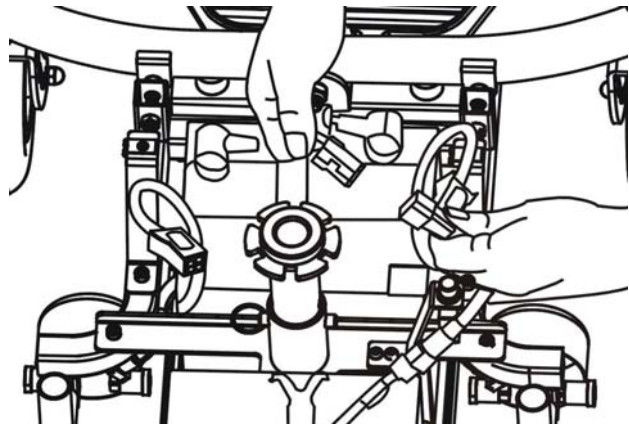

10. Untie safety straps from the batteries.

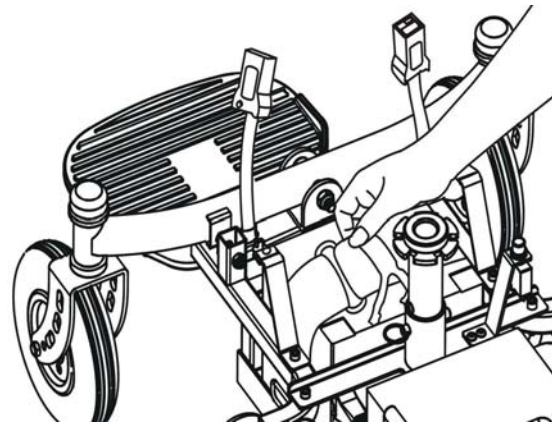

11. Remove the batteries.

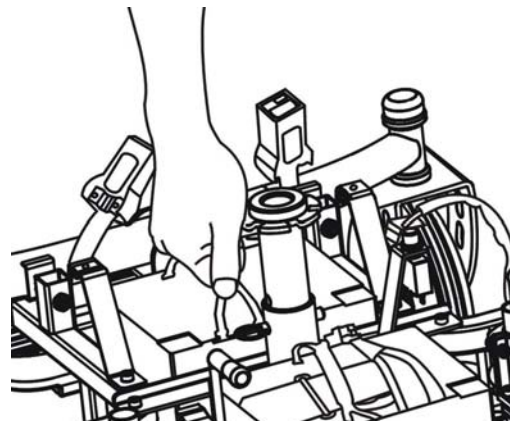

## 7. OPERATION

### GENERAL INFORMATION

1. Make sure that the motor levers are in engaged mode. (Parallel to the wheels)
2. Once seated on the wheelchair, turn on the power (Press the power button). The battery gauge will turn on.
3. We suggest the new users and the disabled operate the chair in low speed until comfortable with the chair and its use.
4. Start to steer, moving the joystick to drive forward, backward, left or right. If you want to stop the wheelchair, release the joystick—it will automatically return to the center position to stop the chair.
5. The chair's speed is automatically reduced by half when the chair is turning.
6. When driving the chair on a slope, push the joystick forward to keep the chair continuously climbing until you reach the top of the slope. While the chair is climbing a steep slope, position your body forward to prevent the front wheels from lifting.
7. When driving the chair down a slope, drive slowly and prepare for an emergency stop if you feel it difficult to control the chair. If the speed increases, release the joystick to slow down or to stop, then start again at a slower speed.

### CONTROLLER

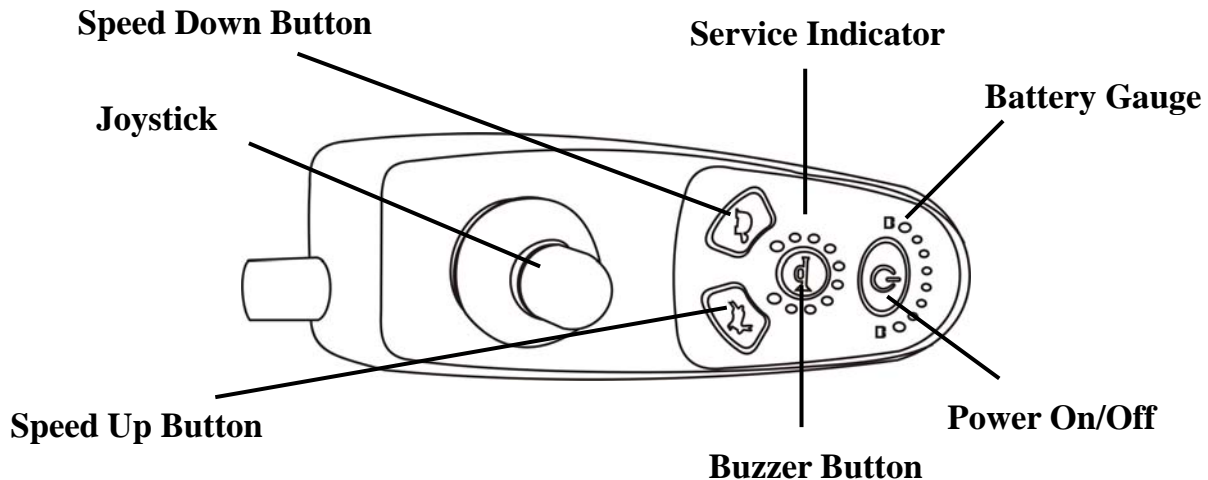

#### ***Battery Gauge***

When the power chair is turned on, the battery gauge will light up as indicated below:

Green lights: the battery has full capacity.

Orange lights: do not drive power-chair for a long trip.

Red lights: the power-chair should be charged as soon as possible.

## **SECURITY FUNCTIONS**

1. The forward/backward/turn speed, acceleration and deceleration are programmable.
2. Thermal overload protection.
3. Current overload protection.
4. The fault diagnostics of the controller (see "Troubleshooting" section).
5. The power-chair will not operate while charging the batteries.

## 8. CHARGER

### Power Indicator

*Green Light: Power On*

### Charging Indicator

*Yellow Light: Charging*

*Green Light: Charge Complete*

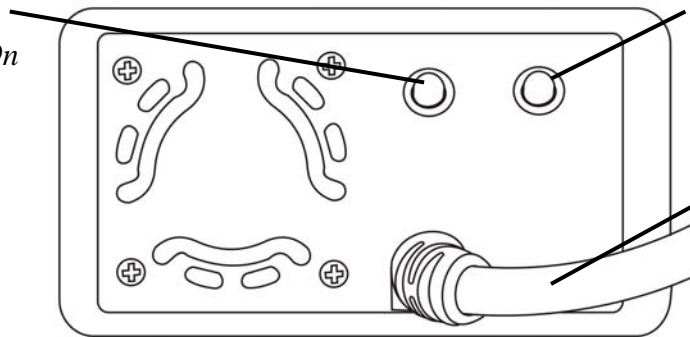

### Charge Cable

### Power Cable Socket

### 115V/230V Switch

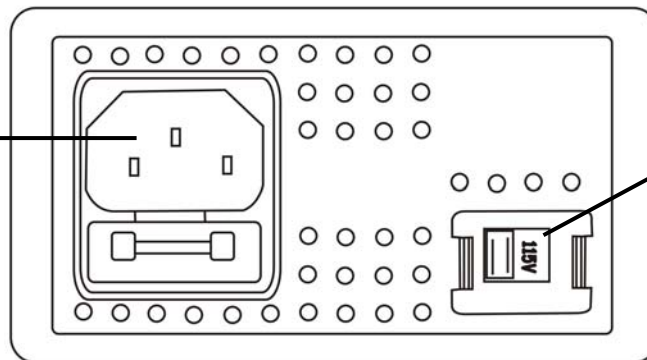

## SPECIFICATIONS

Input Voltage	115V/230V Option Switch 115V(95V-132V)/230V(180V-264V)
Output Voltage	24V
Output Current	3A-6A Continuous
Max. Output Voltage	31V
Protection Against Over-Voltage	Above 32.5V: Automatic Shut-off
Protection Against Overload	Above 8A: Automatic Shut-off
Protection Against Short Circuit	Output Fuse Shuts-off Automatically
Environmental Temperature of use	-10° to 50°
Environmental Temperature of Preservation	-25° to 85°
Dimensions	180mm (L) x 93mm (W) x 53mm (H)
Weight	1.83 lbs.

## **FEATURES**

1. Ensures the battery connection automatically.
2. Monitoring all procedures until the battery is fully charged.
3. For protecting exhausted batteries, slow charge starts in the beginning then fast charge until it goes up to the normal voltage.
4. Compact, portable and light-weight.
5. Approvals: UL, CSA, CE, TUV, JAPAN (T-mark)

## **OPERATION INSTRUCTIONS**

Please follow these steps:

1. Select the correct input voltage (115/230V) on the 115/230V option switch.
2. Assure charging on lead-acid batteries only.
3. Keep the AC power switch off until the battery and charger have been connected.
4. Make sure the output end of the charger corresponds with the positive/negative pole of battery.
5. Turn on the AC power switch to "I" (the fan should begin to run). When LED turns to red/yellow, it means the charger has been under normal charging condition.
6. When LED turns to red/green, it means the battery has been fully charged. The charging procedure has completed.
7. While the yellow/green LED is lit, it may have a temporary alternating occurrence around 1-60 seconds during switching. Please note that this is normal.

## **USAGE ENVIRONMENT**

1. Please keep the charger at least 2 inches away from other objects when charging.
2. Do not use it on wet and dirty surfaces.
3. Do not place the charger on the battery.

## **NOTES**

1. Ensure the output-DC voltage corresponds to the battery type and voltage. Otherwise it may cause an explosion.
2. Switch off the charger before connecting the charger and the battery.
3. Do not expose the charger to the rain, water or near flammable materials. Do not store the charger in humid places or in a closed area.
4. The warranty is given for use within normal operating conditions; it does not cover accidental damage, or problem caused by user's neglect or misuse.

## 9. INSPECTION & MAINTENANCE

### BATTERY

Please charge the batteries after long distance driving to prolong the battery. If you don't drive the chair for along period of time, then charge at least every month. Please use a maintenance/water-free battery to avoid trouble.

### MOTOR

The carbon brush connector & brakes should be replaced regularly.

### ELECTRICAL BRAKES

Testing of the electrical brakes should be carried out on a level floor with at least three feet of clearance space around the power chair.

Power-on the controller, and push the joystick forward slowly until you hear the electrical brake working. The power wheelchair may start to move. Immediately release the joystick, you must be able to hear each electrical brake within a few seconds. Repeat the test three times, pushing the joystick backward, left and right respectively.

### TIRES

Check front/rear tires regularly and replace them when worn out.

** Suggestion**

Tire wear is not covered under your power wheelchair's warranty.

## 10. TROUBLESHOOTING

The diagnostic flash codes for your power chair are designed to help you perform basic troubleshooting quickly and easily. A diagnostic flash code flashes from all 6 of the LED's located on the controller in the event one of the conditions listed below develops.

*Note: "." Denotes a brief flash, "-" denotes a long flash*

**Table 1: Power wheelchair Controller Internal Diagnostics**

<b>Flash Code</b>	<b>Description</b>	<b>Recommended Action</b>
1	Motor Current Over Limit	Motor current is over the controller set limit. Release the joystick to neutral and try again.
2	Battery	Try charging the batteries. Batteries may need replacing. Check the battery cables and connections.
3	Left Motor	Check the left motor cables and connections.
4	Right Motor	Check the right motor cables and connections.
5	Left Parking Brake	Check the left parking brake cables and connections.
6	Right Parking Brake	Check the right parking brake cables and connections.
7	User Interface	Display PCB fault. Consult a service agent.
8	Controller	Consult a service agent.
9	A-series Bus Communication	Consult a service agent.

If more than one fault exists, then the fault having the highest priority (and lowest number of flashes) is indicated. All faults disable the controller and require the controller to be turned off then on again once the source of the fault is removed.

## 11. SPECIFICATIONS

<b>Max. Weight Capacity</b>	300lbs/136kg
<b>Travel Speed/Range</b>	
Speed	4 mph/6 kph
Estimated Range	20 miles/32 km
<b>Maximum Grade/Incline</b>	12°
<b>Turning Radius</b>	31"/788mm
<b>Ground Clearance</b>	3"/75mm
<b>Overall Dimensions</b>	
Length	37"/940mm
Width	23.5"/597mm
Height	42"/1067mm
<b>Seat Dimensions</b>	
Width	18"/457mm
Depth	18"/457mm
Back	29"/737mm
Armrest to Seat	7"/178mm
<b>Power</b>	
Motor	24Vx320Wx2x4600 rpm
Controller	Dynamic A 50 A
Batteries	Two DC12V x 36AH
Battery Charger	5 Amp, Offboard
<b>Brakes</b>	Electromagnetic
<b>Freewheel Mode</b>	Yes
<b>Tires (Foam-filled)</b>	
Front Casters:	8"x2"/200mmx50mm
Rear Drive Wheels:	10"x3"/260mmx85mm
<b>Weights</b>	
Total Wt. (w/o battery)	143lbs/87kg
Battery pack	48lbs/22kg

*User's weight, road conditions, battery charge, etc. will influence performance.*

ActiveCare reserves the right to modify the specifications if necessary. The final specifications are subject to the individual power wheelchair your purchase from your dealer.

## 12. LIMITED WARRANTY

This warranty is extended only to the original purchaser/user of our products. This warranty gives you specific legal rights and you may also have other legal rights which vary from state to state.

ActiveCare warrants this product to be free from defects in materials and workmanship, for the following periods:

<u>Five Years</u>	<u>Three Years</u>	<u>12 Months</u>	<u>6 Months</u>
▪ Base frame	▪ Seat frame	▪ Electronic controllers ▪ Motor & Brake (electronic function only) ▪ Charger ▪ Any other electrical subassembly	▪ Batteries

If within such warranty periods any such part shall be proven to be defective, such part shall be replaced. This warranty does not include any labor or shipping charges incurred in the installation of any such replacement part. ActiveCare's sole obligation, and your exclusive remedy under this warranty, shall be limited to such replacement.

For warranty service, please contact the dealer from whom you purchased your ActiveCare product. In the event you do not receive satisfactory warranty service, please write directly to ActiveCare at this address:

ActiveCare Medical  
2 Harbison Way  
Columbia, SC 29212

Provide dealer's name, address, and date of purchase, indicate nature of the defect and, if the product is serial numbered, indicate the serial number. Do not return products to ActiveCare without our prior consent.

LIMITATIONS AND EXCLUSIONS: THE FOREGOING WARRANTY SHALL NOT APPLY TO SERIAL NUMBERED PRODUCTS IF THE SERIAL NUMBER HAS BEEN REMOVED OR DEFACED, IF THE PRODUCTS HAVE BEEN SUBJECT TO ACCIDENT, MISUSE, ABUSE, NEGLIGENCE, MISHANDLING, MISAPPLICATION, COMMERCIAL USE, ACTS OF GOD, ALTERATIONS OR MODIFICATIONS NOT AUTHORIZED BY ACTIVECARE, INCLUDING BUT NOT LIMITED TO, MODIFICATION THROUGH THE USE OF

UNAUTHORIZED PARTS OR ATTACHMENTS; PRODUCTS DAMAGED BY REASON OF REPAIRS MADE TO ANY COMPONENT WITHOUT THE SPECIFIC CONSENT OF ACTIVECARE, OR TO A PRODUCT DAMAGED BY CIRCUMSTANCES BEYOND ACTIVECARE'S CONTROL, SUCH EVALUATION WILL BE SOLELY DETERMINED BY ACTIVECARE. THE WARRANTY SHALL NOT APPLY TO PROBLEMS ARISING FROM NORMAL WEAR OR FAILURE TO ADHERE TO THESE INSTRUCTIONS. A CHANGE IN OPERATING NOISE, PARTICULARLY RELATIVE TO MOTORS AND GEARBOXES DOES NOT CONSTITUTE A FAILURE. ALL SUCH DEVICES WILL EXHIBIT A CHANGE IN OPERATING NOISE DUE TO AGING.

THE FOREGOING EXPRESS WARRANTY IS EXCLUSIVE AND IN LIEU OF ANY OTHER WARRANTIES WHATSOEVER, WHETHER EXPRESS OR IMPLIED, INCLUDING THE IMPLIED WARRANTIES OF MERCHANTABILITY AND FITNESS FOR A PARTICULAR PURPOSE, AND THE SOLE REMEDY FOR VIOLATIONS OF ANY WARRANTY WHATSOEVER, SHALL BE LIMITED TO REPLACEMENT OF THE DEFECTIVE PRODUCT PURSUANT TO THE TERMS CONTAINED HEREIN, THE APPLICATION OF ANY IMPLIED WARRANTY WHATSOEVER SHALL NOT EXTEND BEYOND THE DURATION OF THE EXPRESS WARRANTY PROVIDED HEREIN. ACTIVECARE SHALL NOT BE LIABLE FOR ANY CONSEQUENTIAL OR INCIDENTAL DAMAGES WHATSOEVER.

THIS WARRANTY SHALL BE EXTENDED TO COMPLY WITH STATE/PROVINCIAL LAWS AND REQUIREMENTS.

## WARRANTY REGISTRATION

### Don't Forget to Complete Your Warranty Form!

Be sure to fill out the form below. After completing the form, please mail it to:

ActiveCare Medical  
2 Harbison Way  
Columbia, SC 29212

*Please type or print*

VIN _____	Date Purchased _____
Owner Name _____	
Address _____	
City _____	State _____ ZIP _____
Signature _____	Telephone _____
Dealer Name _____	Dealer Phone _____
E-mail Address _____	
Comments _____	
_____	