

# Revolutionary

*Provides Unparalleled Freedom For*

# Fusion™

*Your Everyday World*



**Extraordinary Indoor  
Maneuverability**

**Exceptional Outdoor  
Capability**

**Awesome All Day  
Power**

**Luxurious  
Comfortable Seating**

**Attractive Styling**

**Real Transportability**

**Top Reliability**

**Long Term Value**

Specifications	Fusion™ 350	Fusion™ 250
Overall Length	45.5"	
Overall Width	23.5" / 22"	
Weight		
Rear Drive Unit	49.5 lbs. / 47.5 lbs	
Base & Tiller	33 lbs.	
Seat Section	24.5 lbs.	
Batteries	27 lbs.	
Shroud	3.5 lbs.	
Maximum Speed	5 mph / 4.3 mph	
Range	350 lb. rider-up to 20 miles / 250 lb. rider-up to 25 miles	
Ground Clearance	2"	
Turning Radius	29.5"	
Tire Size		
Front	3" x 9" / 2.5" x 9"	
Rear	3" x 9" / 2.5" x 9"	
Seat Dimensions		
Width	18"	
Depth	18"	
Back Rest Height	20"std. or 16"opt.	
Seat Height (From Floorpan)	16.75" to 17.75"	
Electronic Brakes (Regenerative & Dynamic with "Posi-Lock" Disk Brake)	Yes	
Drive Type	Transaxle	
Motor Size	1 1/4 HP Motor / 1HP	
Incline Stability	12° (22% grade)	
Rated Structural Capacity	350 lbs. / 250 lbs.	

Specifications tested to US Ansi/Resna procedures. Incline stability rating by US Ansi/Resna 8.3. Information current at time of publication. We reserve the right to change specifications without public notice. Speed and range may vary with rider weight, battery condition and terrain.

**Lifetime Limited Warranty** on main frame.

**Five Year Limited Warranty** on transaxle.

**Two Year Limited Warranty** on components.

**Battery Warranty** by battery supplier.

See Owners Manual for complete warranty details.

*Your Professional Local PaceSaver® Dealer*

## Color Choices

Ocean Blue

Midnight Black

Candy Apple Red

Velvet Seats

Black

Gray

Plush Vinyl Seats

Charcoal

Gray

## Accessories & Options



Flag



Oxygen Holder



Cup Holder



Saddle Bag



Front Bag

- On-Board Charger
- Cane Holder
- Left Hand Controls
- Lap Belt
- Rearview Mirror
- Cane Seating
- Flat-Free Tires

Reclining Admiral Seat  
with Adjustable Headrest

Candy Apple Red



Please see the Accessories & Options brochure for a complete listing.

**PaceSaver® Scooters! Celebrating 22 years of legendary performance.**

# If you plan to have only one mobility vehicle, its got to be Fusion™!

## Our History

In 1967 Bill & Zella Burke started developing and manufacturing quality health care products. The company that Mr. & Mrs. Burke started employed thirty people, twenty were seniors or disabled and the Burkes received national awards for hiring veterans. Now in our 3rd generation, we continue Mr. Burke's dedication to building reliable, long lasting products and supporting America.



Bill Burke, *PaceSaver*®

## Scooter History

In 1984 we patented the first successful rear-wheel drive scooter that separated for transport, the pioneering PaceSaver®. For over 20 years we have designed and manufactured long lasting, ultra stable, performance scooters. For 20 years the entire industry has made scooters for three basic categories. First, **the indoor scooter** - highly maneuverable, with a small turning radius but much less stable, for very limited indoor use. Most indoor scooters tip easily, especially outdoors in yards or on ramps. Second, **the outdoor scooter** - much more stable and powerful but difficult for indoor use because of the big turning radius. Many outdoor scooter users had to leave their scooter in the garage or kitchen because they are too big for indoor use. Third, **the indoor/outdoor compromise scooter** that tries to balance the design requirements of two opposing environments. Unfortunately, the indoor/outdoor scooter could not excel in both environments and many users were forced to buy two scooters to meet their needs until now. Fusion's patent pending design achieved the industry's 20 year goal of fusing together extraordinary indoor maneuverability with exceptional outdoor stability and awesome all day power into one revolutionary performance vehicle, the Fusion™.

## Fusion™ - The Total Environment Vehicle

We call Fusion™ the Total Environment Vehicle because it is the world's most versatile mobility vehicle providing unparalleled performance for your use in your total environment.

## Extraordinary Indoor Maneuverability

Fusion™ is designed for tight spaces. With a 29.5" turning radius, Fusion™ is more maneuverable than many power wheelchairs and up to **30% more maneuverable** than typical (much less stable) travel scooters. You can easily turn from narrow hallways into small bathroom doorways. Fusion™ can turn completely around in a small kitchen or elevator.

## Exceptional Outdoor Capability

Fusion's patent pending Max-Trax™ design maximizes traction and stability to take you where you want to go. Fusion's Max-Trax™ combines two unique concepts. Max-Trax™ **increases the percentage of traction** on the drive wheel as the rider's weight increases so you can go outback on sand, grass or gravel. Additionally, Fusion's Max-Trax™ stability compensation system can climb long 12° inclines as well as 3" curbs with a 350 lb. rider. This is **the industry's best incline stability** rating (RESNA 8.3 test), 50% better than many scooters.

## Awesome All Day Power

Fusion™ uses 2 full size U1 33 to 35 amp. hr. batteries for a range of up to 20 miles at a speed of 5 mph to provide all day range. Take trips to the doctor, church or the shopping mall. U.S. made super powerful, 110 amp. controller takes a 350 lb. user up long 12° inclines. **All day power** with U.S. made high torque, 4 pole motor. Heavy duty transaxle with 3 brake system can take a 350 lb. person up and down our tortuous 140 yd. 7° - 9° test hill 20 times. That's almost 20 times the number of trips a typical travel scooter can do with their rated weight rider.

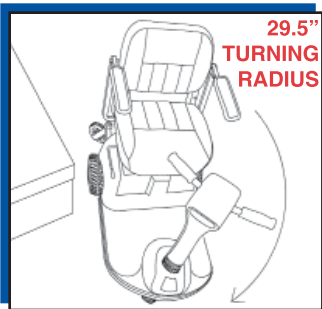

Easily Climbs 3" Curb Cut



12° Inclines



140 yd. Hill



## Luxurious, Comfortable Seating

Fusion's full size orthopedic seats provide superior comfort and body support. The seat's 5" thick wrap around design conforms to your shape minimizing pressure to provide **luxurious, long term comfort and support**. Fusion's full size seating, combined with **longer leg and foot room**, provides superior all day comfort in an extraordinary, maneuverable scooter. Soft touch, easy access, infinitely adjustable tiller provides **relaxed shoulder comfort**. Optional Admiral Seat adds finger tip 35° recline and automotive style coil spring suspension to soak up outdoor bumps. Soft pressure reducing velvet material lets air pass through adding to long term comfort by reducing heat buildup. Specially selected for softness to reduce pressure points, our leather-like vinyl provides for easy transfers and moisture protection.

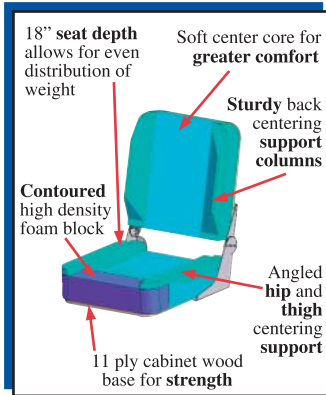

Admiral Seat



## Separates For Transport



## Real Transportability

Fusion™ features our quick and easy single pull pin separation. Fusion™ separates into 3 sections to fit in most cars, vans or SUV's, or you can use our Magnum Lift.

## Attractive Styling With Exclusive MirrorGlaze™ Lasting Beauty

Rich depth of color reflective finish is molded "Through & Through" the body so color won't chip, peel or fade. With "Scratch Guard" easy maintenance, simply wipe with a damp cloth or wax. With the deep clear coat hardened acrylic layer, there is no ugly touch up with paint.

## Fusion™ is American Made

For almost 40 years we have built quality mobility products known for long term value. We stock over 5,000 parts built by Americans in 44 states. Our stock of millions of dollars worth of parts in Kansas City allows us to ship over 90% of our replacement parts within a day. We help get you moving fast even if your unit is decades old. With our Engineering, Production and Service departments only a few yards apart, we provide the most accurate, up to date information to service your product. When you buy a U.S. made medical scooter, you are assured of the highest quality because only plants in the U.S. are regularly inspected by the F.D.A.

## Fusion™ Features

- Revolutionary combination of maneuverability, performance and comfort.
- Great styling - rich, long lasting color and mag wheels.
- Easy to use controls with safety throttle shielding.
- Easy access to charger port, light and basket.
- Extra long foot pass through for transfer and extra leg room for comfort.
- Height adjustable, 360° locking swivel seat with removable flip up, width/height adjustable arm rests for fitted comfort.
- Maximum comfort seating high back (standard). Optional middle back or push button 35° recline Admiral seat.
- Separates easily for transport.
- State-of-the-art U.S. controller for confident, smooth driving with automatic self diagnostic status indicator. Battery saver and power boost functions.
- Controller and connections are enclosed and isolated from tire spray. Controller has moisture and Push-Too-Fast disengage runaway protection.
- Super fast, carry-along, world wide use 4 amp. charger or optional fast charge, onboard, worldwide use 1.7 amp charger.
- Much longer warranties.